

Pressure transmitter with bourdon tube, Type series CK5...



Application area

- Chemical and petrochemical industry
- Safety engineering systems
- Machinery construction

Features

- Pressure transmitter with on-site indication for relative pressure measurements
- Output signal: 4...20 mA (20...4 mA) 2-wire technology
- Integrated angle-of-rotation sensor, not subject to wear
- Safety pattern gauge S3 per EN 837-1, NS 100 and 160, alternative high quality case with bajonet ring per EN 837-1 S1
- Nominal ranges 0...0.6 bar up to 0...1000 bar, -0.6...0 bar up to -1...24 bar
- EAC declaration (upon request)

Options

- Approvals/Certificates
 - Material certificate per EN 10204
 - Calibration certificate per EN 10204
 - Explosion protection
 - Certificate of measuring equipment for Russian Federation
- The electrical measurement range start and end can be adjusted by holding a magnet to a marked location on the case
- Diaphragm seals see product group D5
- Output signal 0...20 mA and 0...10 V in 3-wire technology (for devices without Ex-protection and without adjustment of the electrical measurement range start and end)
- Oxygen free of oil and grease

Application

A mechanical safety pattern gauge with local indication and an integrated electronic angle-of-rotation sensor for the electronic transmission of pressure values. It is a non-contact sensor and therefore completely free from wear and friction. The pressure transmitter is suited for measuring the relative and absolute pressures of gases, vapors and liquids.

Technical data

Constructional design / case

Design:	High quality case with bajonet ring per EN 837-1 S1, material: stainless steel mat.-no. 1.4301 (304) ; with blow-out device, Material: Desmopan Alternative: High quality safety case with blow-out back and solid baffle wall per EN 837-1 S3, material: stainless steel mat.-no. 1.4301 (304)
Nominal size:	NS 100 or NS 160
Degree of protection per EN 60529:	<ul style="list-style-type: none">■ Without filling: IP 65■ With filling S1 case: IP 65■ With filling S3 case: IP 66
Case filling:	Labofin
Window:	Non splintering laminated glass
Connection plug:	Waterproof terminal box with removable test cover (Macrolon). Cable gland for cable from Ø 7...13 mm.
Weights:	DN 100: With filling: approx. 1.9 kg Without filling: approx. 1.1 kg DN 160: With filling: approx. 2.4 kg Without filling: approx. 1.2 kg

Process connection

Design:	Standard G1/2 B radial at bottom. For further process connections see order details.
---------	---

Material wetted parts

Measuring element:	Bourdon tube and shanks stainless steel mat.-no. 1.4571 / 1.4404 (316Ti / 316L)
--------------------	---

Measuring system

Movement:	Stainless steel segment
Scale:	Pure aluminium, white with black inscription Optional with red marking or with fixed reference pointer. Special scale upon request
Pointer:	Pure aluminium, black, with micro adjustment for zero point correction

Nominal range

Nominal ranges:	See order details
Overload protection:	1.3 times For higher overload protection see order details.

Accuracy

Accuracy class:	1,0 per EN 837-1 (for nominal ranges < 1000 bar) 1,6 per EN 837-1 (at nominal range = 1000 bar)
Signal current error:	< 1 % of measuring span
Temperature influence:	On zero point and meas. span: ≤ 0.04 % f.s. / K

Output

2-wire technology

Signal:	4...20 mA (20...4 mA)
Burden R:	$R = U - U_{\min} / 0.022 \text{ A} [\Omega]$ U = supply $U_{\min} = \text{min. supply voltage } 12 \text{ VDC}$

3-wire technology

Signal:	0...20 mA und 0...10 V Other output signals upon request
Burden R:	<u>for current output</u> $R = U - 3 \text{ V} / 0.020 \text{ A} [\Omega]$ U = supply <u>for voltage output</u> $R \geq 500 \text{ kOhm}$

Supply voltage

2-wire technology

Nominal voltage:	24 V DC 12...30 V DC
Function area:	

3-wire technology

Nominal voltage:	24 V DC 14...30 V DC
Function area:	

Temperature ranges

	Without filling	With filling
Ambient:	-20...70 °C	-20...70 °C (60 °C) ¹
Media: ²	-20...100 °C	-20...100 °C
Storage:	-40...70 °C	-40...70 °C

Extended temperature ranges (optional):

	Without filling	With filling
Ambient:	-40...80 °C	-40...80 °C (60 °C) ¹
Media: ²	-40...100 °C	-40...100 °C
Storage:	-40...80 °C	-40...80 °C (60 °C) ¹

¹ Safety case S3

² Nominal ranges ≤ 1 bar up to 100 °C

Tests and certificates

Ex-protection: For integrated angle-of-rotating
81.4 Type PL 1100
TÜV 08 ATEX 554749
⊕ II 2G Ex ib IIC T6/T5/T4 Gb
⊕ II 2D Ex ib IIIC T 75 °C / T 95 °C /
T 115 °C / T 120 °C Db
 $U_i \leq 30 \text{ V DC}$ $I_i \leq 150 \text{ mA}$ $P_i \leq 1 \text{ W}$

The effective internal capacitances and inductances are negligibly small.

For detailed Information see Ex Safety Instruction XA_009.

Ex-protection (ATEX) for mechanical devices:

⊕ II 2G c TX

⊕ II 2D c TX

For detailed Information see Ex Safety Instruction XA_005.

- EAC declaration upon request
- Certificate of measuring equipment for Russian Federation

Connection diagram

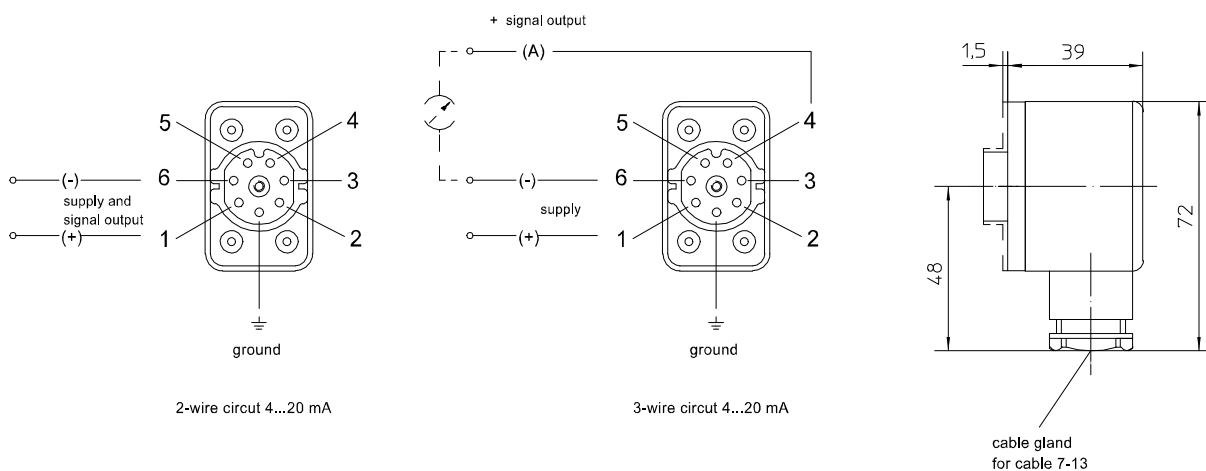

Settings

Setting the zero on the mechanical indicator

Set the mechanical zero at its operating temperature and in the depressurized state. Open the bayonet ring on the case by turning it with a strap wrench in the anti-clockwise direction. Then remove the bayonet ring together with glass and gasket. By turning the micro adjustment on the pointer you can zero-adjust the pointer. Anti-clockwise rotation causes a negative correction; and clockwise rotation a positive correction.

Important: The position of the pointer is altered by this mechanical adjustment. Now that the pointer has been repositioned the electrical zero needs to be corrected.

Adjustment of electrical measurement range start and measurement range end (optional)

The electrical setting of the measurement range start is done under application of the measurement range start pressure. For the adjustment, the magnet enclosed in the cable socket, or another magnet, is brought into the offset position. After approx. 2 seconds, a light signal acknowledges in the scale the adjusted measurement range start. For adjusting the span (measurement range end), the measurement range end pressure needs to be applied, e.g. 10.0 bar. You have to bring a magnet into the offset position. After approx. 2 seconds, a light signal in the scale acknowledges the adjusted span.

Important: Adjustment is possible within a tolerance window of approx. $\pm 5\%$ F.S. Settings deviating from this are not taken on.

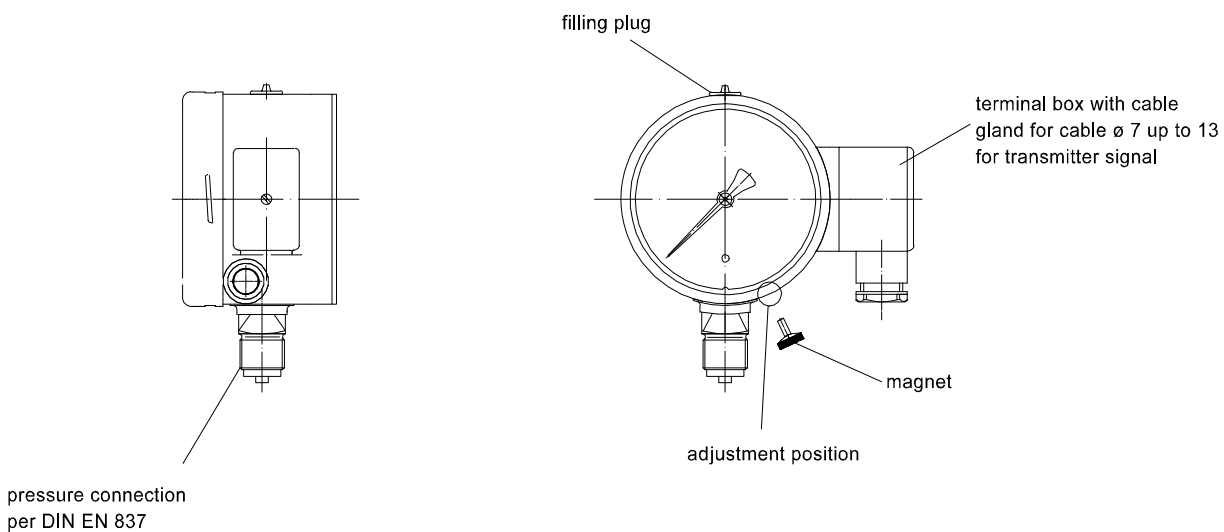

Dimensions

Safety pattern gauge EN 837-1 S1

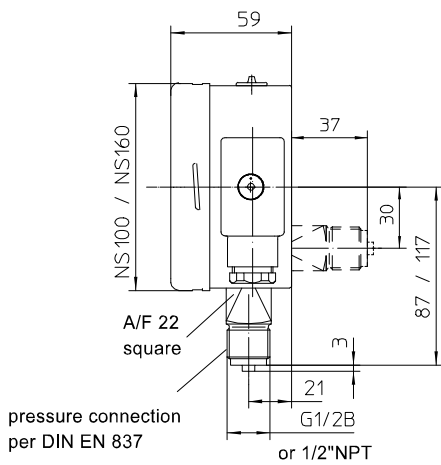

pressure connection per DIN EN 837

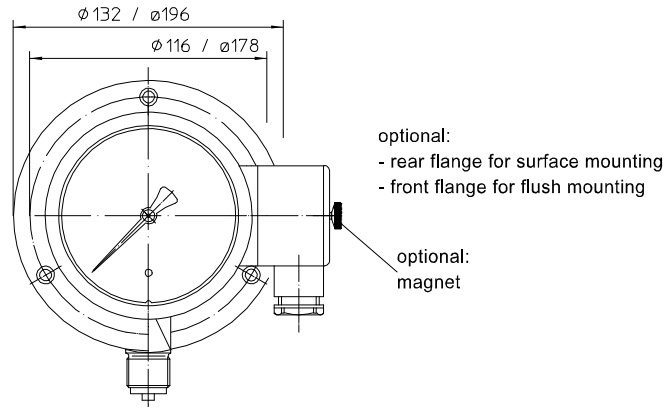
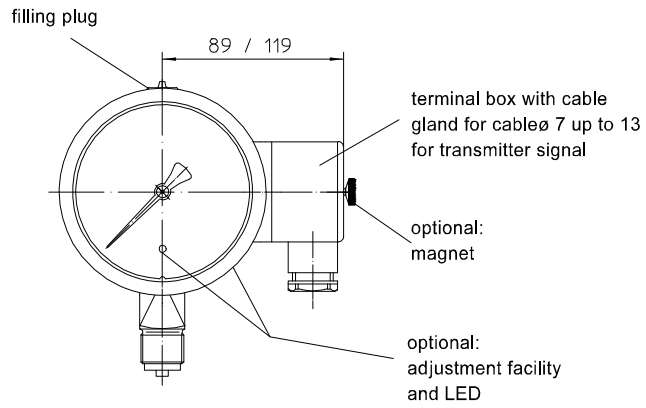
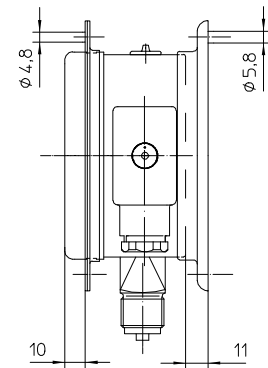

Safety pattern gauge EN 837-1 S1 with solid baffle wall and blow-out back

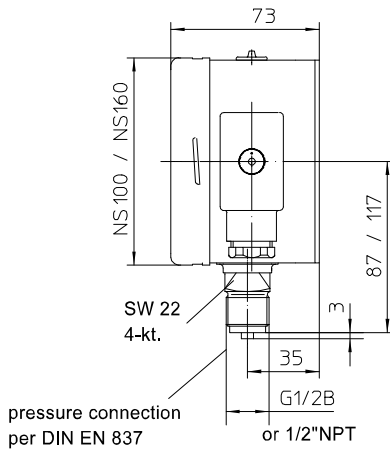

pressure connection per DIN EN 837

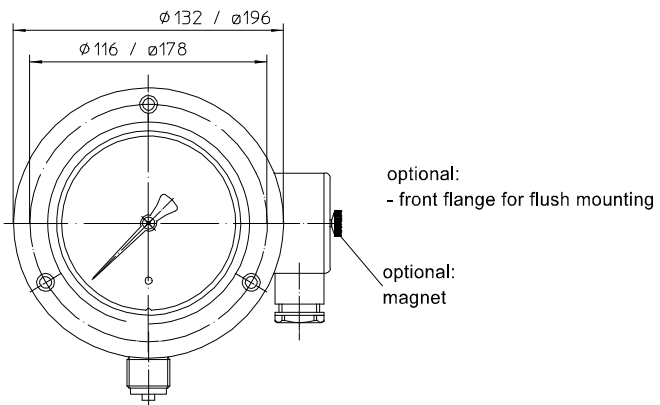
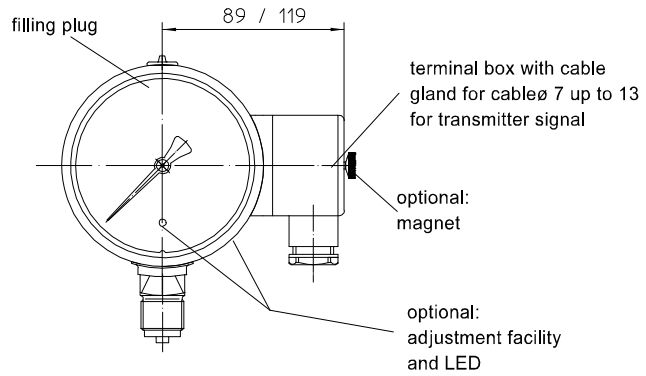
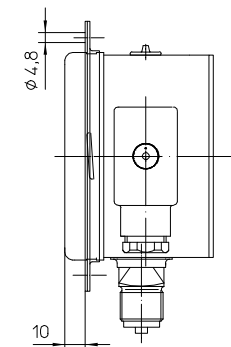

All dimensions are in mm

Order details

Pressure transmitter, safety pattern gauge, Type series CK5

Order code CK5						
CK520.	safety case NS 100	EN 837-1 S1 with blow-out device	degree of protection IP 65	without liquid filling	process connection bottom	
CK521.					process connection at back	
CK522.				with liquid filling	process connection bottom	
CK523.					process connection at back	
CK550.		EN 8371-1 S3 with solid baffle wall and blow-out back	degree of protection IP 65 degree of protection IP 66	without liquid filling	process connection bottom	
CK554.				with liquid filling		
CK530.	safety case NS 160	EN 837-1 S1 with blow-out device	degree of protection IP 65	without liquid filling	process connection bottom	
CK531.					process connection at back	
CK532.				with liquid filling	process connection bottom	
CK533.					process connection at back	
CK560.		EN 8371-1 S3 with solid baffle wall and blow-out back	degree of protection IP 65 degree of protection IP 66	without liquid filling	process connection bottom	
CK564.				with liquid filling		
0	Ex-protection	standard				
1		Ex-protection, type of protection as follows				
A2 . . .	process connection	G1/2 B				
B2 . . .		1/2" NPT				
C2 . . .		M 20 x 1.5				
085	nominal ranges (bar)	-0.6...0				
086		-1...0				
087		-1...0.6				
088		-1...1.5				
089		-1...3				
090		-1...5				
091		-1...9				
092		-1...15				
093		-1...24				
052		0...0.6				
053		0...1				
054		0...1.6				
055		0...2.5				
056		0...4				
057		0...6				
058		0...10				
059		0...16				
060		0...25				
061		0...40				
062		0...60				
063		0...100				
064		0...160				
065		0...250				
066		0...400				
068		0...600				
070		0...1000 ¹				
K1		output signal	0...20 mA, 3-wire technology ²			
K2			4...20 mA, 2-wire technology			
K3			0...10 V, 3-wire technology ²			
K4			20...4 mA, 2-wire technology			

Additional features (to be indicated if required)			
S72	type of Ex-protection ³	⊕ II 2G Ex ib IIC T6/T5/T4 Gb	⊕ II 2G c TX
S74		⊕ II 2D Ex ib IIIC T75 °C/T95 °C/T115 °C/T120 °C Db	⊕ II 2D c TX
F1	electrical zero setting ³	by attaching a magnet to the housing, with LED confirmation,	reference point = lower range value
F9			varying reference point , please specify
H2	overload protection	2times (measuring ranges 1...4 bar)	
H3		2times (measuring ranges 6...40 bar)	
H4		1.5 times (measuring ranges 60...160 bar)	
R2	window	safety glass with max. pointer	
R3		safety glass with adjustable reference pointer	
T2	marking	on scale (pls specify)	
T3		fast reference pointer (pls specify)	
V2	mounting	rear flange for surface mounting	
V3		front flange for flush mounting	
W1020	material certificate	per EN 10204-3.1, wetted parts	
W1201	calibration certificate	per EN 10204-3.1, 5 measuring points	
W2673	certificate of measuring equipment for Russian Federation		
W4001	oxygen free of oil and grease		
W4090	extended temperature ranges		
Z1	connection to Zone 0 ⁴	with Zone 0 adapter (coupler element KF6)	

Order code (example): CK5500 - A2063 - K2 - ...

¹ accuracy class 1.6 per EN 837-1

² for devices without Ex-version and without adjustment of measurement range start and end

³ only with 2-wire technology

⁴ only for devices in Ex-version