

1 General information

Diaphragm seals are components in pressure measuring instruments which prevent the measured medium from entering the measuring system. Measuring problems, which are often impossible to solve with the pressure gauge itself, can be solved by selecting the correct diaphragm seal system. Here are some examples:

- protection of the measuring instruments from aggressive, viscous, solidifying or crystallizing media
- protection from high medium temperatures or fluctuations in temperature
- protection of measuring devices from vibrations by coupling via capillaries
- damping of measurement pressure fluctuations and pressure peaks
- dead-zone free measuring arrangements for particular hygienic applications
- use of special materials or surface coatings of the wetted parts for special applications

2 Operation

The operation of a diaphragm seal is based on the principle that a pressure (p) acts on a liquid via a diaphragm with minimum deflecting force. This liquid then acts on the measuring element of a pressure measuring instrument (see below).

Almost all pressure gauges can be combined with diaphragm seal systems, including mechanical pressure gauges and transmitters. These measuring devices are driven via a suitable diaphragm seal liquid and therefore do not come into contact with the measured medium.

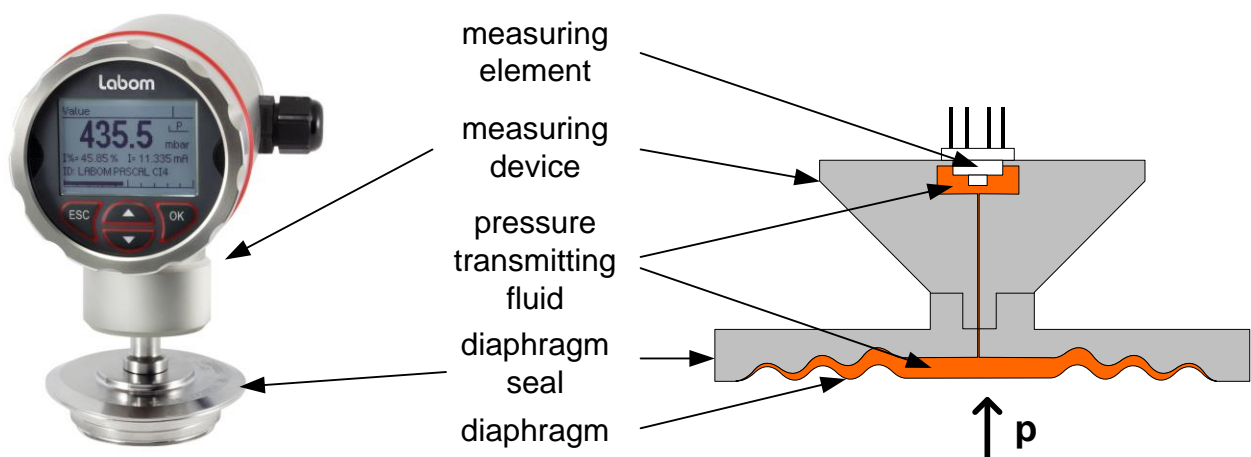

The zero point stability of a measuring instrument with connected diaphragm seal is influenced by the volume change of the filling liquid caused by changes in temperature. These volume changes must be absorbed by the deflection of the diaphragm. Thus, the rigidity of the diaphragm causes a change in the internal system pressure, what results directly in a displacement of the zero point. Normally, a zero point drift caused by temperature cannot be

compensated, so that the rigidity of a diaphragm seal directly influences the measurement accuracy.

3 Diaphragm seal body and diaphragm

The shape of the diaphragm seal depends on the special requirements of the process in question. Diaphragm seals can have the following shape: flange-type diaphragm seal, screw-type diaphragm seal, diaphragm seal with extension, inline diaphragm seal.



Diaphragm seal systems with diaphragms from stainless steel or special materials are very resistant to chemical influence. A further protective measure is coating with PTFE foils, PFA or gold coating.

Fig. 2 shows the typical inner pressure gradient of a LABOM flat diaphragm seal. The permissible working volume of a diaphragm seal generally lies in the flat section of the characteristic curve.

working volume

$$V_A = V_2 - V_1 \quad [\text{cm}^3]$$

The pressure increase in the working range of a diaphragm seal can, with sufficient accuracy, be considered as linear and is defined as

rigidity

$$S = \frac{\Delta P}{V_A} \quad [\text{mbar/cm}^3]$$

Fig. 2

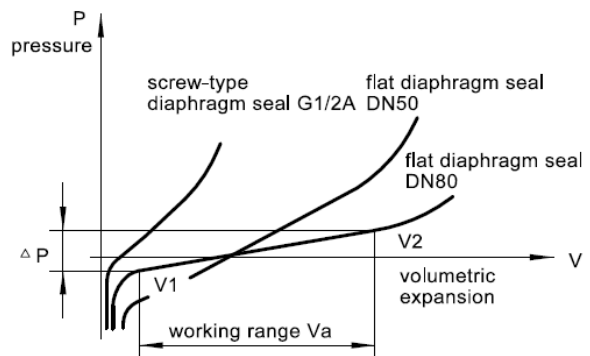

Our diaphragm seal systems are filled with volumes that have been specifically calculated for the system. The technology available today allows us to dose the system contents with an accuracy of 1.0 mm³. Diaphragm seal systems are generally suitable for vacuum and designed for processes temperatures from -10 to +140 °C.

Depending on the system design, medium and ambient temperatures can result in significant zero-point displacements at the measuring device. If necessary, we can provide you with a detailed error calculation.

4 Diaphragm technology

It is the diaphragm itself that determines the characteristics of the diaphragm seal. These characteristics are critical for the design and error analysis of a diaphragm seal system. In the error analysis, diaphragm rigidity is the most important property. This property is essentially a function of the following parameters:

- Material strength
- Material
- Nominal diameter
- Shape of diaphragm

In particular, there are three diaphragm technologies available for flat diaphragm seals:

- Standard sinusoidal shape
This type of diaphragm is suitable for all designs and nominal sizes. When made of stainless steel, this diaphragm type is available with a great variety of standard coatings. Their major advantages: they are easy to manufacture and their thermal characteristics can be readily and accurately determined.
- Self-compensating diaphragm (patented)
The self-compensating diaphragm was developed for special diaphragm materials such as tantalum and Hastelloy. This type of diaphragm almost completely compensates for temperature-related fluctuations in the volume of transmission fluids located behind the diaphragm seal. Even with high diaphragm thicknesses (0.1 mm), diaphragm seal systems fitted with self-compensating diaphragms have significantly better thermal characteristics than those fitted with standard sinusoidal types. All designs specifying special diaphragm materials can be constructed with a self-compensating diaphragm.
- LTC Technology (patented)
Diaphragms with Low Temperature Coefficient (LTC) technology are especially robust stainless steel diaphragms which exhibits almost no deflection force within their working range. The great strength of the materials used to construct this type of diaphragm make it mechanically robust and resistant to chemicals, cleaning processes and aggressive media.

The diaphragm size directly influences the rigidity and therefore the temperature error. The bigger the diaphragm, the smaller the temperature error.

- active diaphragm surface approx. Ø 85mm
→ process temperature error < 0.1 mbar / 10 K
(= 0.01 % / 10 K at 1000 mbar nominal range)
- active diaphragm surface approx. Ø 65 mm
→ process temperature error < 0.2 mbar / 10 K
(= 0.02 % / 10 K at 1000 mbar nominal range)
- active diaphragm surface approx. Ø 50 mm
→ process temperature error < 0.4 mbar / 10 K
(= 0.04 % / 10 K at 1000 mbar nominal range)

5 Mounting instruction

- Do not remove the protective cap or protective wrapping from the diaphragm before immediate installation to prevent soiling or damage.
- Do not touch the diaphragm with your fingers or other objects. Do not place the device on its diaphragm. Even small scratches or deformations may negatively influence the zero point or other characteristics of the device.
- Pressure transmitter and diaphragm seal are a closed system that must not be separated.
- The gasket should not rest on or press against the surface of the diaphragm. Any pressure on the diaphragm will be registered as a process pressure, which means that a gasket that is incorrectly positioned or too small will result in incorrect measurements. Ensure that the gasket is properly positioned on its sealing surface.

6 System with capillary

The connection between measuring instrument and diaphragm seal should be made via a capillary if the instrument must be kept away from unacceptable levels of temperature or vibration. At the same time, be aware that capillary tubes produce a throttling effect which is often desirable in the case of pulsating process pressures.

When measuring below atmospheric pressure, the device should be positioned at the same height as, or even better, below the diaphragm seal. This avoids problems with the liquid column due to its own hydrostatic pressure.

If only overpressures will be measured, the measuring device can also be mounted above the measuring point. Under atmospheric conditions, the maximum difference in height should not exceed four meters.

For pressure values close to 0 bar absolute it is mandatory to mount the measuring device below the diaphragm seal.

The factory settings are made with the pressure transmitter and diaphragm seal at the same height. You can correct zero-shifts caused by height differences of device and diaphragm seal using the zero-point correction at the device.

Fig. 3: Recommended installation for level measuring

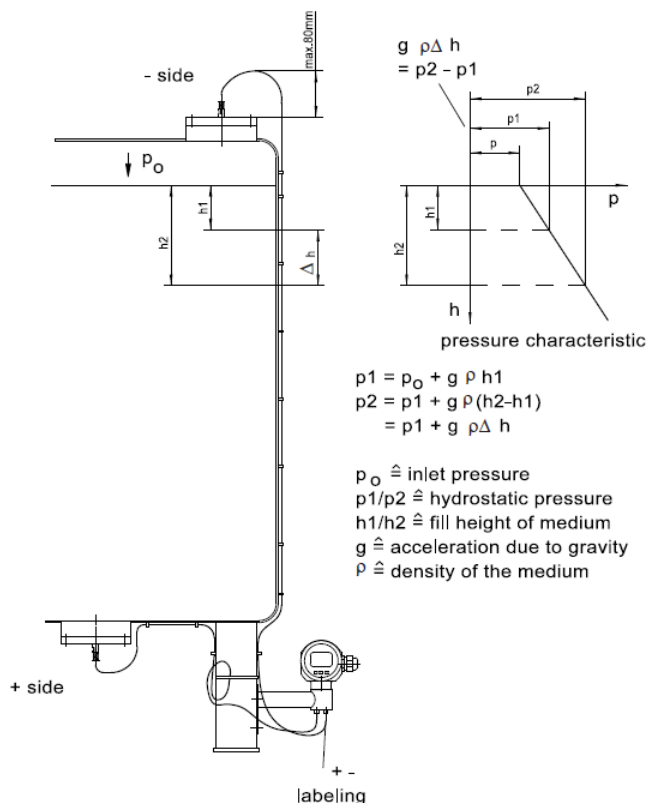

6.1 Mounting the capillary

Due to its own weight, the transmission fluid in the capillary has an inherent mass inertia.

If liquid columns in capillaries are subjected to mechanical accelerations such as from vibrations or shocks, pressure pulsations and surges will occur in the system. These pulsations and surges can result in measurement errors. In this regard, it does not matter whether the diaphragm seal system is subjected to an applied gauge pressure (process pressure) or not.

To minimize these effects, the capillary must be securely routed and mounted so that it is not affected by vibrations or shocks. Any extra length of tube should be rolled up with a radius of at least 30 cm.

Fig. 4: Mounting the capillary

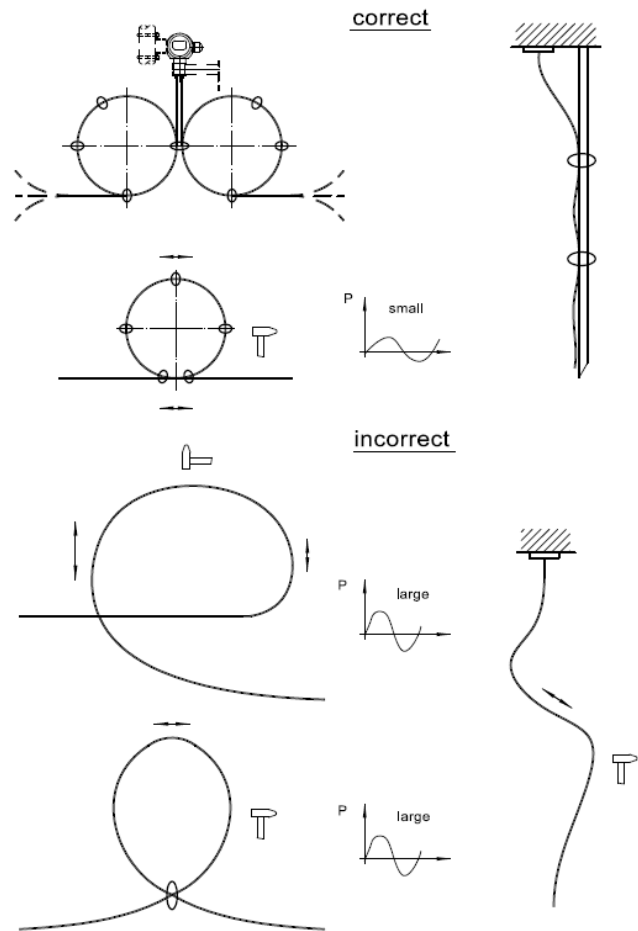

7 Pressure transmission fluid

Depending on the application, a variety of liquids with different properties are available. The following table contains typical values, recommended application areas and features of the respective transmission fluid. For further information - especially limits for negative pressure applications - see TA_038.

Code	Description/Application	Type	t _{min} [°C]	t _{max} [°C]	density [g/cm ³]	kin. viscosity @ 40°C [mm ² /s]	Tk [%/10K]	compress- ibility [%/100 bar]
FD1	silicon-free oil suitable for food stuff applications	polyalphaolefine oil	-40	230	0,82	31	0,76	0,6
FV3H	vacuum and high temperature oil	highly refined mineral oil	-10	400	0,87	95	0,73	1
FC	Halocarbon oil for oxygen applications	halogenated carbon chains	-30	190	1,92	56	0,9	0,73
FM50	silicone oil M50	high viscosity silicone oil	-50	300	0,96	40	0,95	1,02
FM5	low temperature silicone oil M5	low viscosity silicone oil	-90	160	0,92	4	1,08	1,2
FW	white oil for food stuff applications	low viscosity paraffin	-10	170	0,85	43	0,76	0,6
FGW	glycerine/water mixture	glycerine/water 70/30	-30	110	1,18	8	0,57	0,29
FAW	alcohol/water mixture for the paint industry	isopropanol/water 40/60	-20	75	0,95	1,9	0,52	0,81
FMH1	metal liquid for high temperatures or pressures	low melting alloy	0	350	6,44	1,4	0,126	0,02

8 Welding instructions

The following notes are intended solely as information. They are based on the AD instruction sheets for welding on pressure vessels.

Allow adequate cleanliness in welding and do not use rusty objects (screws, tools, etc).

Use enough forming gas to prevent contamination while tacking around in the tank or in the pipeline.

Use for the subsequent welding pure argon as a protective gas.

Weld first opposing sections (see sketch) and allow it to cool down before continuing with the next section.

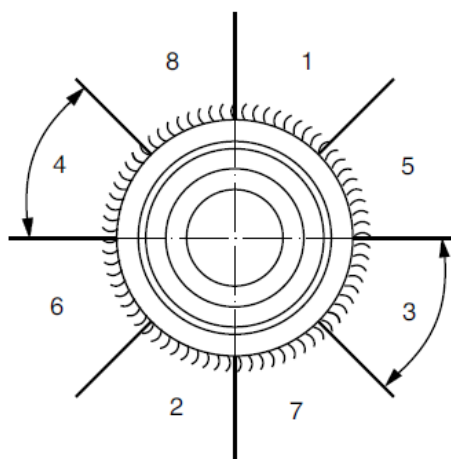

9 Maintenance instructions

Under standard service conditions, diaphragm seal systems require no maintenance. We recommend an annual recalibration.

Upon request, diaphragm seal systems can also be sent in to the manufacturer for examination and/or maintenance. Applicable occupational safety and health regulations specify that only clean (free of production residue) diaphragm seal systems may be handled at the manufacturer.

Contaminants such as adhering process media should be removed with suitable solvents and a soft brush.

Please refer to the declaration of contamination, available on our website www.labom.com\Service.

10 Hazardous areas

In hazardous areas, the permissible ambient temperature limits for the measuring instrument must not be exceeded, see the document "ATEX Safety Instructions" for the measuring device for details.

When mounting diaphragm seals with flame arresters for connection to Zone 0, the working temperature of 60 °C for the measuring instruments must not be exceeded.