

Resistance thermometer MiniTherm for installation in a separate thermowell Type series GA2730



SIL2

Application area

- Pharmaceutical industry
- Food industry
- Biotechnology

Features

- Resistance thermometer for the installation in a separate thermowell
- Measuring insert spring loaded
- Compact and small design
- Fast response
- Measuring resistor 1 x Pt100 or 2 x Pt100, class A
- Circular connector M12 or field housing

Options

- Approvals/Certificates
 - Ex-protection (ATEX/CCCEX)
 - Classification per SIL2
 - Calibration certificate per EN 10204-3.1
- As per UKCA regulations
- Various transmitters can be integrated
- Output signal 4...20 mA via transmitter PA2430
- Output signal IO-Link V1.1 via transmitter PA2530
- Extended neck tube
- Process connection union nut G3/8"

Application

The resistance thermometer MiniTherm is designed for the installation in a separate thermowell. Suitable thermowells see data sheets of the type series HP1100, HP1110 and HP1200. Because of its compact design MiniTherm is suitable for use in a great number of technological processes.

Technical data

Constructional design

Design:	Measuring insert \varnothing 3 mm spring loaded and union nut M12x1 Alternative with extended neck tube
Material:	Measuring insert: Stainless steel mat.-no. 1.4404 (316L) Union nut: Stainless steel mat.-no. 1.4301 (304)
Length of measuring insert:	See order details
Degree of protection per EN 60529:	IP 67
Electrical connection:	Circular connector M12 (4-pin) Option: Circular connector M12 (8-pin) for 2 x Pt100 Field housing with screw cap Mat.: stainless steel mat.-no. 1.4305 (303)
Measuring resistor:	<ul style="list-style-type: none">■ Pt100 per EN 60751, class A 3-wire■ Pt100 per EN 60751, class A 4-wire (3-wire bridged)■ 2 x Pt100 per EN 60751, class A 3-wire

Accuracy

Pt100:	Per EN 60751, class A
Response time:	Per EN 60751, test procedure with flowing water, Measuring insert: $t_{90} = 3$ s Including separate thermowell, type series HP1200 (pipe 6 x1 mm): a) without heat sink compound $t_{90} = 15$ s b) with heat sink compound $t_{90} = 6$ s

We recommend the use of heat sink compound.

Temperature ranges

Design with circular connector M12 and field housing:

Ambient:	-40...85 °C
Media:	-50...200 °C
Storage:	-40...85 °C

Design with transmitter:

Ambient:	-20...80 °C
Media:	-50...200 °C
Storage:	-20...80 °C

Transmitter

Installation variants:	<ul style="list-style-type: none">■ Transmitter, Type PA2430, for circular connector M12■ Transmitter, Type PA2530 IO-Link, for circular connector M12■ Transmitter head mounted, Type series PA210., 4...20 mA, programmable■ Transmitter head mounted, Type series PA220., electrically isolated, classification per SIL2■ Transmitter head mounted, Type series PA230., electrically isolated, classification per SIL2, HART®■ Transmitter head mounted, Type series PA2420, 2 channel, classification per SIL2/3, HART®
------------------------	--

Tests and certificates

Ex approval

ATEX:	TÜV 08 ATEX 554093 X ⊕ II 1G Ex ia IIC T6/T5/T4 ⊕ II 2G Ex ib IIC T6/T5/T4 ⊕ II 1D Ex iaD 20 T89 °C ⊕ II 2D Ex ibD 21 T129 °C $U_i \leq 30$ V $P_i \leq 200$ mW Ci and Li are negligible small (not for devices with transmitter)
CCCEX:	CCCEX No. 2022322315004603 Ex ia IIC T6...T4 Ga Ex ib IIC T6...T4 Gb Ex ia IIIC T89 °C Da Ex ib IIIC T129 °C Db
UK:	Intrinsically safe per EN 60079-11, P5.7 simple electrical apparatus

Further technical data see Ex Instructions XA_001 (ATEX) and XA_029 (CCCEX).

SIL2:	Functional safety: per EN 61508, classification of Pt100 sensor per SIL2, suitable transmitter upon request
-------	--

Connection diagram

Circular connector M12

1 x Pt100, 3-wire

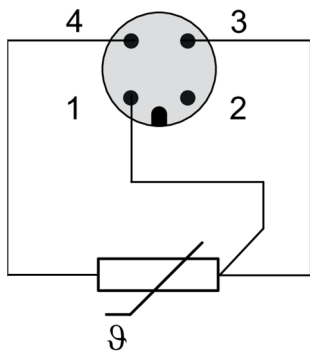

1 x Pt100, 4-wire
(3-wire bridged)

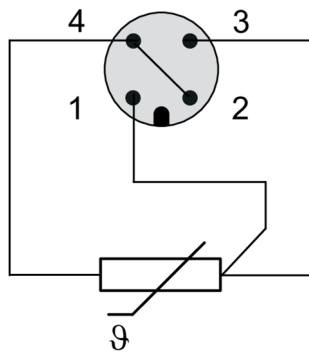

2 x Pt100, 3-wire

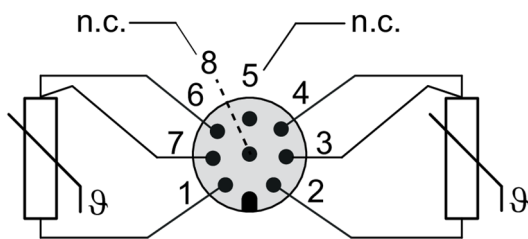

Transmitter
(type series PA2430)

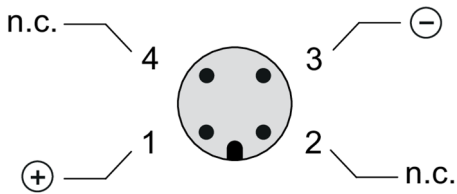

Transmitter IO-Link
(type series PA2530)

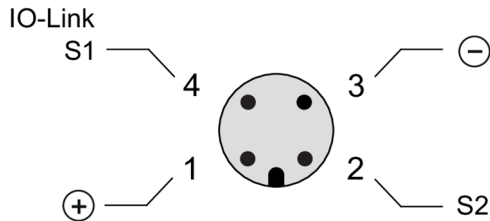

Terminal block / cable gland

1 x Pt100, 3-wire

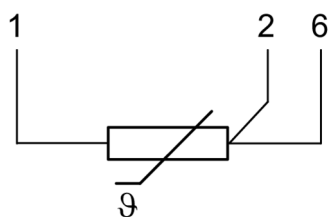

2 x Pt100, 3-wire

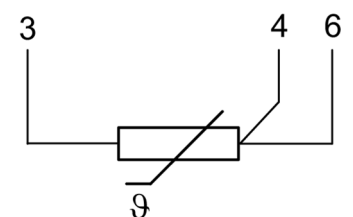
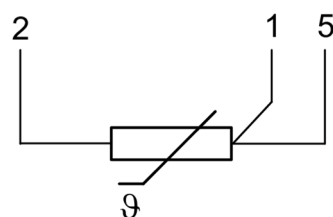

Dimensions

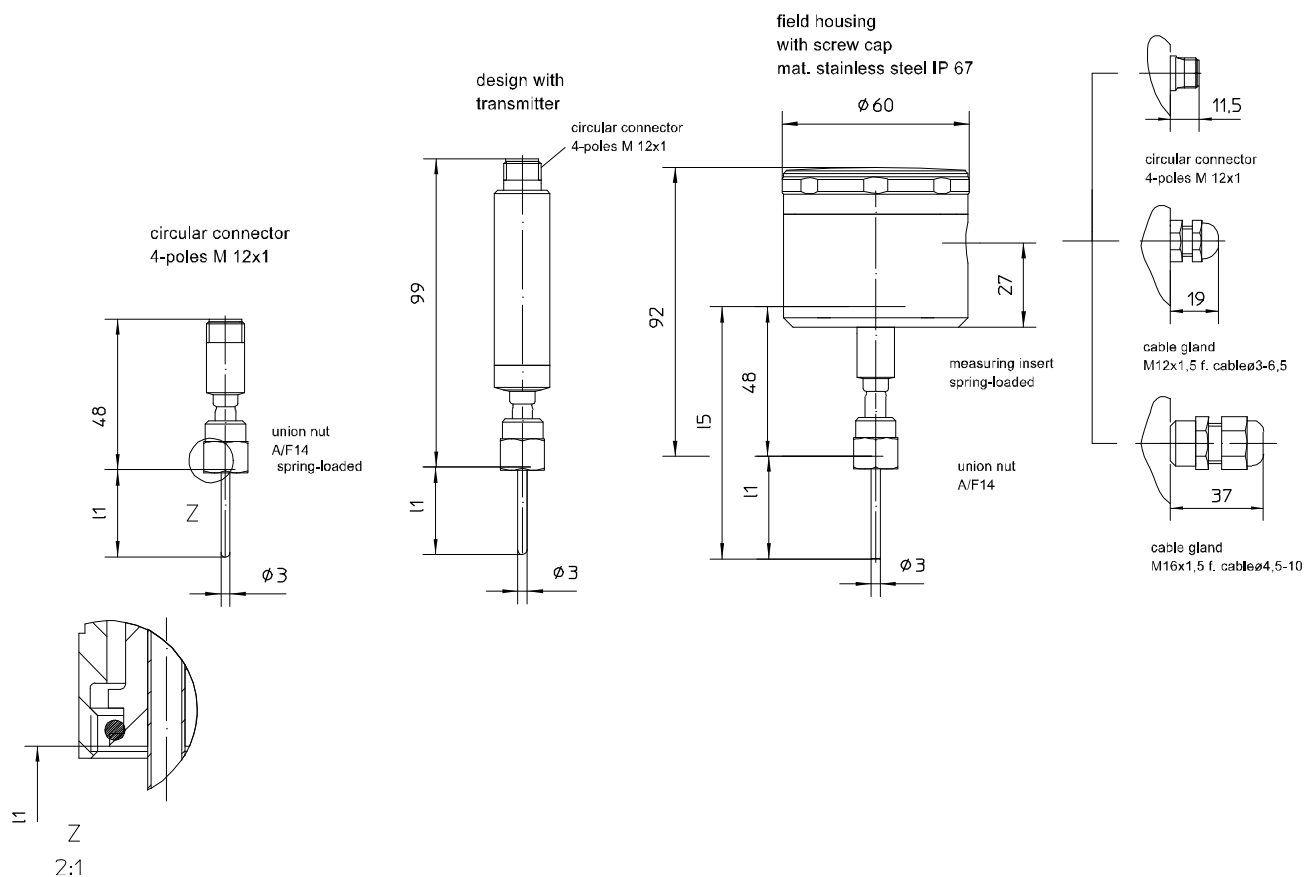

All dimensions are in mm

To determine the installation length I1, see:

Thermowell HP1100, data sheet DB_T5-050





Thermowell HP1110, data sheet DB_T5-052

Thermowell HP1200, data sheet DB_T5-051

For the design with neck tube the insertion length I1 has to be extended by M (length neck tube), (see order details, additional features, order code V1xxx).

Order details

Resistance thermometer MiniTherm for installation in a separate thermowell			
GA2730	resistance thermometer MiniTherm for installation in a separate thermowell		
A10	instrument connection	union nut M12x1	
A50		union nut G3/8"	
C3...	temperature sensor	Ø 3 mm	
028	insertion length l1 ¹	28 mm	
038		38 mm	
060		60 mm	
084		84 mm	
161		161 mm	
...		required insertion length up to 250 mm can directly be ordered, e.g. l1: 100 mm, order code 100	
M2	tolerance	class A per EN 60751	
N2	measuring resistor	Pt100 3-wire	
N3		Pt100 4-wire (3-wire bridged) ²	
N5		2 x Pt100 3-wire ^{3,4,5}	
T150	electrical connection	circular connector M12 x 1 (4-pin)	
T151		circular connector M12 x 1 (8-pin)	
T47		field housing Ø 60 mm	cable gland M12 x 1.5 polyamide black for cable Ø 3-6.5
T47.40			cable gland M16 x 1.5 polyamide black for cable Ø 4.5-10
T47.21			cable gland M12 x 1.5 stainless steel for cable Ø 3-6.5
T47.51			with circular connector M12 x 1 (4-pin)
T47.52			with circular connector M12 x 1 (8-pin) ⁴

Additional features (to be indicated in case of need, only)			
V1070	neck tube (M12 x 1)	length of neck tube M = 70 mm	
V1080		length of neck tube M = 80 mm	
V1999		length of neck tube M (in mm)	
S71	Ex-protection	ATEX	 II 1G Ex ia IIC T6 /T5/T4 Ga
S72			 II 2G Ex ib IIC T6 /T5/T4 Gb
S73			 II 1D Ex ia IIIC T89 °C Da
S74			 II 2D Ex ib IIIC T129 °C Db
S100			CCCEX
S101		Ex ib IIC T6...T4 Gb	
S102		Ex ia IIIC T89 °C Da	
S103		Ex ib IIIC T129 °C Db	
S52		Intrinsically safe per EN 60079-11, P5.7 simple electrical apparatus (UK)	
Z1		incl. transmitter	mounting in field housing (selection of transmitter see product group T4)
Z52	with output signal 4...20 mA (Type PA2430) ^{4,6,7}		
Z54	with output signal IO-Link (Type PA2530) ^{4,6,7}		
W1201	calibration certificate	per EN 10204-3.1, 5 measuring points	
W2604	functional safety per IEC/EN 61508, classification of Pt100 element per SIL2		
W2660	as per UKCA regulations ⁸		

Order code (example): GA2730 – A10 – D1209 – T47 - ...

¹ insertion length > 250 mm upon request

² not possible in combination with transmitter type PA2xxx (order code Z52 and Z54)

³ thermowells with insertion length U1 ≥ 40 mm required

⁴ not for devices with Ex-protection

⁵ requires circular connector M12 x 1, 8-pin (order code T151)

⁶ not for devices with classification per SIL2

⁷ not possible with circular connector M12 x 1, 8-pin (order code T151)

⁸ not possible with thermowell systems with inner pipe diameter > 25 mm