

**Application area**

- Shipping
- Machinery construction
- Chemical and petrochemical industry
- General process technology

Features

- High quality case with bajonet ring NS 100/160, degree of protection IP 66
- Nominal ranges -40 °C...700 °C, further nominal ranges from -200 °C...700 °C upon request
- Case and wetted parts of stainless steel
- Different connections can be supplied
- Temperature detecting element 6, 8 and ≥ 10 mm diameter
- Short immersion lengths of the temperature detecting element may be used
- Accuracy class 1 as per EN 13190
- Micro adjusting pointer for indication correction

Options

- Approvals/Certificates
 - Explosion protection (ATEX/UKEX) for mechanical devices
 - Calibration certificate as per EN 10204
- As per UKCA regulations
- Case with liquid filling
- Electronical angle-of-rotation sensor, Type series PL1100, see data sheet D6-020
- Connection to zone 0 with thermowells (upon request)

Application

These thermometers are suitable for use outdoors and in aggressive environments. The devices can also be supplied with additional liquid damping for use in extreme conditions. Suitable thermowells see product group T5.

Technical data

Constructional design / case

Design:	High quality case with bajonet ring, material: stainless steel mat.-no. 1.4301 (304)
Nominal size:	NS 100 or NS 160
Degree of protection per EN 60529:	IP 66
Case filling:	Labofin Further filling liquids upon request.
Case seal:	Material gasket: NBR
Window:	Non-splintering laminated glass. Option: non-splintering plastic (Macro-lon) with adjustable reference pointer
Movement:	Stainless steel with compensation
Scale:	Pure aluminium, white with black inscription. Alternatively with marking or fixed reference pointer.
Pointer:	Pure aluminium, black with micro adjustment for zero point correction
Weights:	Bottom or centre back connection

NS 100:

without filling:	approx. 0.6 kg
with filling:	approx. 0.8 kg

NS 160:

without filling:	approx. 1.1 kg
with filling:	approx. 1.9 kg

Adjustable angel stem

Without screwing and temperature detecting element

NS 100:

without filling:	approx. 1.0 kg
with filling:	approx. 1.2 kg

NS 160:

without filling:	approx. 1.4 kg
with filling:	approx. 2.0 kg

Process connection

Design:	<ul style="list-style-type: none">rigid temperature detecting element, bottom connection.rigid temperature detecting element, centre back connection.rigid temperature detecting element, adjustable angle stem, latching every 20°. <p>Various process connections can be supplied (see order details).</p>
---------	--

Measuring element

Measuring element:	Bourdon tube, dead zone free with noble gas filling.
--------------------	--

Temperature sensor

Temperature-detecting element:	Diameter 6, 8 and ≥ 10 mm. Standard lengths and active lengths see order details, further sizes upon request Material: stainless steel mat.-no. 1.4404 (316L)
--------------------------------	---

Nominal range

Nominal range (EN 13190):	-40...700 °C Measuring spans ≥ 60 °C, see order details Further nominal ranges from -200 °C up to 700 °C (no normal range) upon request.
---------------------------	---



Accuracy

Accuracy class:	1.0 per EN 13190
-----------------	------------------

Temperature ranges

Ambient:	Per EN 13190. Ambient temperatures that deviate from EN are to be specified.
Storage and transport:	-20...60 °C Further temperature ranges upon request.

Tests and certificates

Explosion protection:	Ex-protection (ATEX/UKEX) for mechanical devices  II 2G Ex h IIC T1...T6 Gb X  II 2D Ex h IIIC Txx°C Db X
-----------------------	---

Further details and temperature limits see Ex Instruction XA_005.

Instructions for use

The loading capacity of the temperature detecting element depends on the following parameters:

- Media
- Media pressure
- Media temperature
- Flow velocity
- Insertion length
- Material

A technical examination might be necessary as well as the use of a separate thermowell (Product group D5).

Information on other models see order details or upon request.

Further information to mounting and operation see Operating Instruction BA_017.

Dimensions

Dimensions bottom and centre back connection

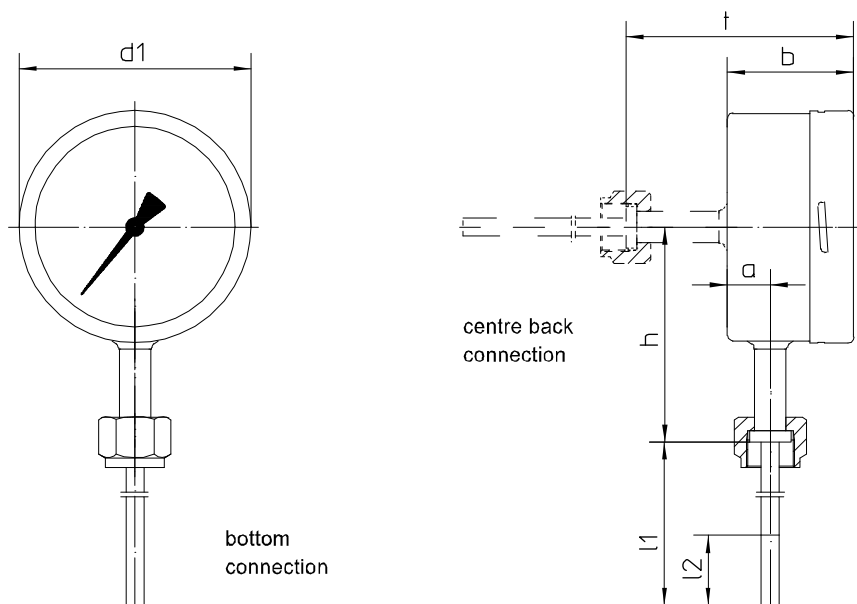

Temperature detecting element diameter d_5 , insertion length l_1 and active length l_2 see order details.

Dimensions (mm)														
				h^*	see order details					t^*	see order details			
case	d_1	b	a	D1001	D1107/1109/1122	D1207	D2007	D2009	D1001	D1107/1109/1122	D1207	D2007	D2009	
NS 100	100	59	15	98	83	98	98	98	108	93	108	108	108	
NS 160	160	60	15	128	113	128	128	128	108	93	108	108	108	

* For nominal ranges ≥ 160 °C dimension increases by 36 mm.

Dimensions adjustable angle stem

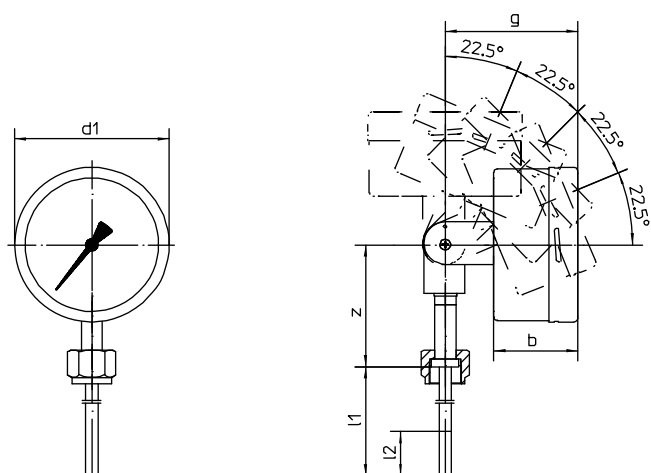

Temperature detecting element diameter d_5 , insertion length l_1 and active length l_2 see order details.

Dimensions (mm)				z' see order details				
case	d_1	b	g	D1001	D1107/1109/1122	D1207	D2007	D2009
NS 100	100	59	92	83	68	83	83	83
NS 160	160	60	92	83	68	83	83	83

* For nominal ranges ≥ 160 °C dimension increases by 36 mm.

Dimensional drawing of process connections for bottom connection, centre back connection and adjustable angle stem

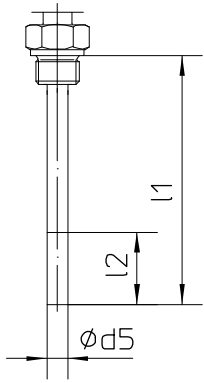

shanks, fixed
G1/2B, G3/4B,
1/2" NPT
D1107/1109/1122

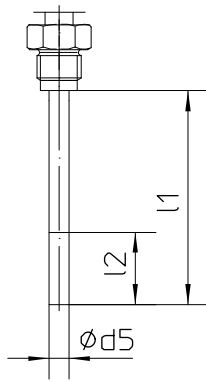

shanks
rotating,
G1/2B
D1207

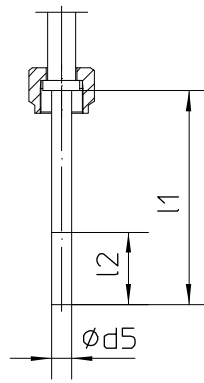

union nut
G1/2
D2007

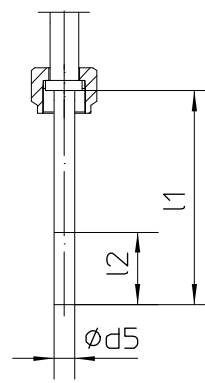

union nut
G3/4
D2009

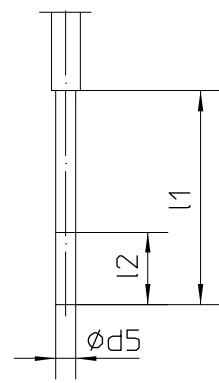



without
screwing
D1001

Order details

Gas expansion thermometer Type series FN....

Order details FN....						
FN2400	case design degree of protection IP 66	bottom connection	NS 100	without liquid filling		
FN3400			NS 160			
FN2600			NS 100	with liquid filling		
FN3600			NS 160			
FN2300		centre back connection	NS 100	without liquid filling		
FN3300			NS 160			
FN2500			NS 100	with liquid filling		
FN3500			NS 160			
FN2310		adjustable angel stem	NS 100	without liquid filling		
FN3310			NS 160			
FN2510			NS 100	with liquid filling		
FN3510			NS 160			
		nominal ranges	measuring ranges			
A2340	standard ranges [°C], accuracy class 1 per EN 13190	-20...40	-10...30			
A2346		-20...60	-10...50			
A2322		-30...50	-20...40			
A2220		-40...40	-30...30			
A2222		-40...60	-30...50			
A2520		0...60	10...50			
A2522		0...80	10...70			
A2524		0...100	10...90			
A2540		0...120	20...100			
A2544		0...160	20...140			
A2548		0...200	20...180			
A2560		0...250	30...220			
A2565		0...300	30...270			
A2627		0...400	50...350			
A2630		0...500	50...450			
A2640		0...600	100...500			
A2650	0...700	100...600				
D1107	process connection	shank, fixed	G1/2 B			
D1109			G3/4 B			
D1122			1/2 NPT			
D1207		shank, rotating	G1/2 B			
D2007		union nut	G1/2			
D2009			G3/4			
D1001		without screwing				
F6	temperaturing detecting element Ø d5	6 mm (l2 ≥ 180 mm) ¹				
F8		8 mm (l2 ≥ 80 mm) ¹				
F10		10 mm (l2 ≥ 50 mm) ¹				
	insertion lenght l1 (mm) ²	D11.. shank fixed	D1207 shank rotating G1/2 B	D2007 union nut G1/2	D2009 union nut G3/4	D1001 without screwing
...		100	080	089	093	100
...		160	140	126	130	160
...		250	230	186	190	250
...		400	380	276	280	400
...		-	-	426	430	-
999		deviating length; please specify				

Additional features (to be indicated if required)		
S30	Ex-protection (ATEX/UKEX) for mechanical devices ³	 II 2G Ex h IIC T1...T6 Gb X
		 II 2D Ex h IIC Txx°C Db X
R13	window	macrolon with adjustable reference pointer ⁴
T2	marking	on scale (please specify)
T3		fixed reference pointer (please specify)
W1204	calibration certificate	per EN 10204-3.1, 3 measuring points
W1201		per EN 10204-3.1, 5 measuring points
W2660	as per UKCA regulations	

Order code (example): **FN2400 - A2524 - D1107 - F6100 - ...**

¹ the active length l2 shall reach the media temperature completely. The insertion length l1 should have adequate size.

² standard insertion length to be specified in order code, e.g. Ø d5= 6 mm, l1 = 100 mm: order code F6100

³ within the temperature limits according to Ex instruction XA_005

⁴ not for devices with Ex-protection