

## Pressure transmitter PASCAL CV

for diaphragm seal operation, robust

Type series CV312.-.....D..



### Features

- Modular pressure transmitter with diaphragm seal technology. Output signal:
  - 4...20 mA
  - HART® protocol (rev. 6), option
  - PROFIBUS PA, option
- Function modules
  - Multifunctional display with 5-segment digital display and bar graph
  - Switching module with 2 flating channels, maximum 0.5 A switching current, electrically isolated at all sides, without additional auxiliary power
- Function module replacement on site without recalibration "plug and measure"
- Various process connections
- Limits of measuring range 0...80 mbar to 0...100 bar
- Accuracy  $\leq 0,15\%$
- Turndown 5:1
- Degree of protection IP 66, piezoresistive measuring cell directly aerated

### Options

- Labom REconnect quick coupling device for easy and safe separation and connection of diaphragm seal systems; Type series MK1000, see data sheet D6-022
- Approvals/Certificates
  - Explosion protection (ATEX/IECEX/UKEX) for gases and dust
  - Material certificate as per EN 10204-3.1
  - Calibration certificate as per EN 10204-3.1
  - Classification per SIL2
- As per UKCA regulations
- Degree of protection IP 69K



### Application area

- Chemical and petrochemical industry
- General process engineering
- General process technology

### Application

The modular pressure transmitter PASCAL CV is suited for measuring the relative and absolute pressures of gases, vapors and liquids. The diaphragm seal with flange connection is applicable for pressure measurement with aggressive, highly viscous, solidifying or crystallising media.

### PASCAL CV - the modulare pressure transmitter

#### Basic module

4...20 mA

PROFIBUS PA



#### Function modules

Switching module

HART®-module

Display module



## Technical data

### Measuring ranges

Up to a turndown of 5:1 the measuring span can be freely selected.

Nominal range	Measuring span		Overload capacity **	Lower measuring range limit ***
	min.	max.		
0...0.4 bar *	80 mbar	0.8 bar	1 bar rel.	600 mbar abs
0...1 bar *	0.2 bar	2 bar	3 bar rel.	100 mbar abs
0...4 bar rel. *	0.8 bar	5 bar	10 bar rel.	100 mbar abs
0...16 bar rel. *	3.2 bar	17 bar	60 bar rel.	100 mbar abs
0...40 bar rel. *	8 bar	41 bar	100 bar rel.	100 mbar abs
0...100 bar rel.	20 bar	101 bar	200 bar rel.	0 mbar abs
0...4 bar abs	0.8 bar abs.	4 bar abs.	10 bar abs.	30 mbar abs
0...16 bar abs	3.2 bar abs.	16 bar abs.	60 bar abs.	30 mbar abs

\* Short term or sporadic measurement in vacuum range permitted up to lower measuring limit. Lower range value up to -1 bar rel. adjustable.

\*\* High overload protected designs are available upon request.

\*\* Vacuum-proof designs are available upon request.

### Constructional design / case

Design:	Two-chamber case design with screw cap. Minimum case volume, excellent moisture and condensate protection
Material:	Stainless steel mat.-no. 1.4301 (304)
Degree of protection:	per EN 60529 <ul style="list-style-type: none"> <li>■ IP 66</li> <li>■ optional: IP 69K</li> </ul>
Climatic category:	4K4H per EN 60721 3-4
Pressure compensation:	PTFE filter system
Window:	Non splintering plastic: Makrolon
El. connection:	Screw terminal 1 mm <sup>2</sup>
Cable gland:	<ul style="list-style-type: none"> <li>■ Cable gland M16, material: PA</li> <li>■ Circular connector M12</li> </ul> <p>Further details see order code and upon request.</p>
Weight:	Standard device without diaphragm seal and function modules approx. 0.65 kg

case design:

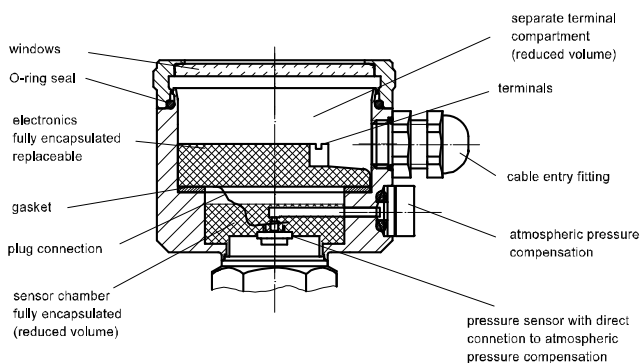

### Process connection

Construction:	Welded design, Variants see order details
---------------	--

### Material wetted parts

Material:	Stainless steel mat. no. 1.4435 (316L/316)
Gasket:	EPDM-FDA listed (in case of flush mounted diaphragm with O-ring)

### Measuring system

Sensor:	Piezoresistive measuring element
System filling:	Synthetic oil FD1, free of silicone, FDA compliant

### Accuracy

<u>General:</u>	
Limit point setting:	per DIN 16086
Reference conditions:	per EN 60770-1
Linearity errors:	≤ 0.15 % of span TD 5:1 no modification
Hysteresis:	≤ 0.05 % of nominal range
Repeatability:	≤ 0.05 % of nominal range
Calibration position:	Vertical mounting position
Influence of mounting position:	≤ 3.5 mbar
Long-term drift: (EN 60770-1)	≤ 0.1 % / year of nominal range

Temperature influence case: Lower range value / upper range value  
 Range 0...60 °C:  
 ± 0.15 % / 10K of nominal range  
 Range < 0 °C, > 60 °C:  
 ± 0.2 % / 10K of nominal range

Temperature influence process connection:

Depending on design

Diaphragm seal	Zero point error
DN 25/1"	4.8 mbar/10K
DN 32/1 1/2"	2.3 mbar/10K
DN 40	1.6 mbar/10K
DN 50/2"	0.6 mbar/10K

Inline diaphragm seal	Zero point error
DN 25/1"	9.5 mbar/10K
DN 32/1 1/2"	4.1 mbar/10K
DN 40	3.9 mbar/10K
DN 50/2"	3.9 mbar/10K

The specified zero error for the process connection is a guide value for a standard design. We can provide a detailed system calculation upon request. Systems with reduced diaphragm seal errors are also available.

## Output

### General:

Delay time: approx. 160 ms  
 Measuring cycle: 6 measurements / second  
 Measuring range setting: Turndown 5:1  
**Basic module: 4...20 mA**  
 Signal: 4...20 mA, 2-wire  
 Current range: 3.8...20.8 mA  
 Current limitation: approx. 22 mA  
 Alarm state: < 3.6 mA, optional > 21 mA  
 Damping: 0...120 seconds  
 Load R:  $R \leq (U-12V \text{ DC})/0.022 \text{ A } [\Omega]$   
 U = supply voltage

### Basic module: PROFIBUS PA

Signal: digital per IEC 61158-2  
 Protocol: EN 50170-PROFIBUS PA, Profile 3.0  
 Sensor address: 0...126 (126 = factory setting)  
 Power consumption: constantly 11 mA  
 Alarm current I<sub>FDE</sub>: 2 mA  
 Damping: 0...300 seconds

Parameterisation: SIMATIC PDM

## Supply voltage

Basic module: **4...20 mA**      **PROFIBUS PA**  
Standard design:  
 Functional range: 12...40 V DC      9...32 V DC  
Ex-design:  
 Functional range: 12...30 V DC      9...17.5 V DC

## Temperature ranges

Ambient: -20...85 °C  
 Media: up to 125 °C, short term up to 140 °C  
 with temperature decoupler up to 160 °C  
 with capillary up to 350 °C  
 Storage: -40...85 °C

Note safety values as per examination certificate!

## Tests and certificates

Interference emission: per EN 55011  
 Noise immunity: per EN 61326-1 \*, NAMUR NE21 \*

\* Devices with cable gland or switching outputs might suffer from a short-time measuring deviation if exposed to strong electromagnetic fields (EN 61000-4-3).

### Ex approvals

ATEX: TÜV 04 ATEX 2387 X  
 Ⓢ II 1/2G Ex ia IIC T4/T5/T6 Ga/Gb  
 Ⓢ II 2G Ex ia IIC T4/T5/T6 Gb  
 Ⓢ II 2D Ex ia IIIC Txx °C Db  
 UKEX: CML 21UKEX21176X  
 Ⓢ II 1/2G Ex ia IIC T4/T5/T6 Ga/Gb  
 Ⓢ II 2G Ex ia IIC T4/T5/T6 Gb  
 Ⓢ II 2D Ex ia IIIC Txx °C Db

For detailed Information see Ex Safety Instruction XA\_015 and XA\_020.

SIL2: Functional safety per EN 61508, Classification per SIL2.

For basic module 4...20 mA, switching module, display module and HART® module

TÜV-Reg.-No. 44 799 13190201

## Function modules

### Display module (multifunctional display) optional

pluggable with automatic module detection - plug and measure -

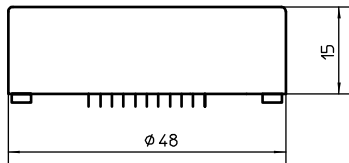
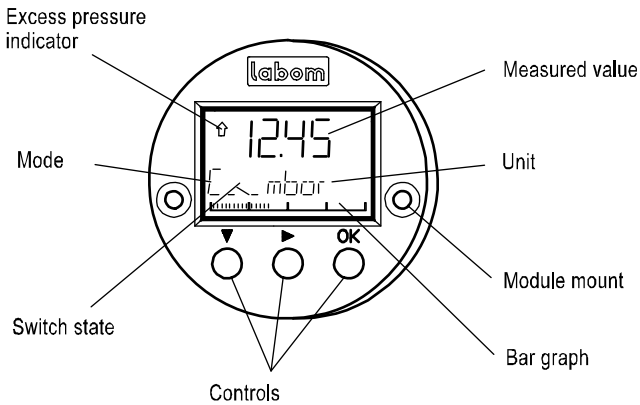

- Module housing made of ABS, encapsulated electronics unit
- Many operating mode menus
- 5-segment pressure read-out with unit
- Read-out display
  - pressure (standard)
  - percent \*
  - current \*
  - sensor temperature
- Bar graph 36 segment suitable 0...100 %
- Loop test (current sensing function) 3.55...22 mA \*
- Alarm indicator on display
- Switching function indicator\*

\* not with basic module PROFIBUS PA

Details of the operator menu see parameterisation.

### HART® module (for basic module 4...20 mA) optional

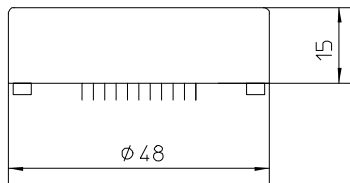
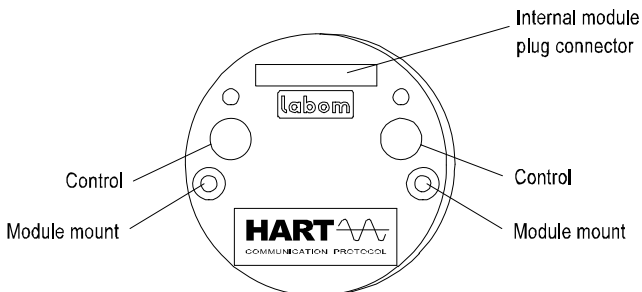

- HART®-protocol, revision 6.5
- Response characteristic FSK
- Load with HART® communication
  - with Hart® modem 230...500  $\Omega$
  - with Hart® communicator 230...1100  $\Omega$
- Parameterisation via
  - operating elements
  - HART® communication
- PDM 6.0
- AMS
- 375 Field Communicator

## Switching module, (not with basic module PROFIBUS PA) optional

pluggable with automatic module detection - plug and measure -

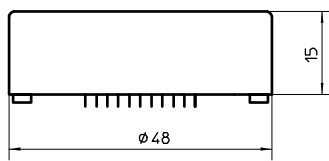
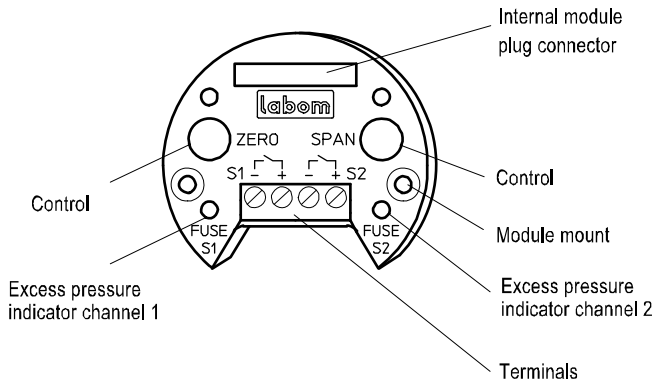

- No additional auxiliary power required
- Module housing made of ABS, encapsulated electronics unit
- Electronic switch for 2 limit values, voltage free, short-circuit-proof
- Switching capacity 30 V DC / 0.5 A ( $R_i < 0.3 \Omega$ )
- Indicator: red LED, indicates overload or short-circuit
- Cut-out fuse protects against overload / short-circuit with automatic reset
- Switch points: 0.0 - 100.0% adjustable, Standard: 50.0%
- Switching function: maker or breaker, adjustable, Standard: breaker
- Contact open when device switched off
- Hysteresis: 0.0...100 % adjustable, Standard 0.1 %
  - falling or rising, adjustable, standard: falling
- Switching rate: 6 Hz
- Electrically isolated to all sides, Insulation voltage: 500 V, 2.5 kV/2 sec.
- Electrical connection: terminal blocks 1 mm<sup>2</sup>

## Hysteresis functions

-falling hysteresis-

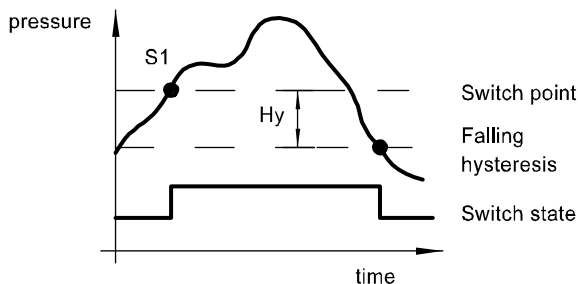

-rising hysteresis-

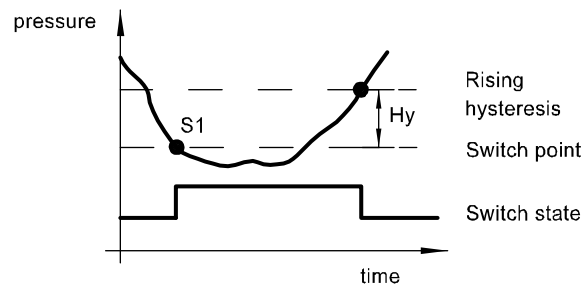

Description of switching module and HART® module upon request.

## Parameterisation

The module selected determines which parameters can be set

operating menus	display of display module	parameter		basic module: 4...20 mA				basic module: PROFIBUS PA		
		variability	standard	BM	SM	AM	HM PDM AMS 475	BM	AM	PDM
zero point *	RANGE/Zero	see instrument ranges	0 bar	x	x	x	x	-	-	x
measuring span *	RANGE/Span	see instrument ranges	nominal range	x	x	x	x	-	-	x
damping	DAMP	4...20 mA: 0...120 sec. Profibus: 0...300 sec.	0 sec.	w	-	x	x	-	-	x
min-max-value	HI/LO	pressure and temperature reset-table	-	-	-	x	x	-	x	x
characteristic	FUNC	linear, table	linear	w	-	x	x	-	-	x
pressure unit	UNIT	bar, mbar, kPa, MPa, mmH2O, mH2O, kg/cm2, PSI	bar	w	-	x	x	-	w	x
loop test	LOOP	3.55...22 mA	-	-	-	x	x	-	-	-
alarm state	ALARM	< 3.6 mA, > 21 mA	< 3.6 mA	w	-	x	x	-	-	-
current trimming	I-CAL	-2...5 %	-	-	-	x	x	-	-	-
pressure trimming	P-CAL	zero point: -50...50 % v.N span: -10...10 % v.N	-	-	-	x	x	x	x	x
table function	TABLE	2...31 points of table	0% = 4 mA 100% = 20 mA	w	-	x	x	-	-	-
system info	INFO	software, serial number, revision level	-	-	-	x	x	-	x	x
factory data reset	RESET	-	-	-	-	x	x	-	x	x
BUS adress	BUS	0...126	126	-	-	-	-	w	x	x
switch points	SWCH1(2)	0...100 % of nominal range	50 %	-	x	x	x	-	-	-
hysteresis	SWCH1(2)/Hyst.	0...100 % of nominal range	0,1 % hyster. falling	-	w	x	x	-	-	-
switch function	SWCH1(2)/SwTyp	breaker, maker	breaker	-	w	x	x	-	-	-
HART® address	HART/Adres	0...63	0	-	-	x	x	-	-	-
HART® current	HART/CUrr	fixed/float	float	-	-	x	x	-	-	-
write protection	-	ON/OFF	OFF	x	x	x	x	x	x	x

x = configurable

w = factor setting

\* = calibrated measuring span for devices with PROFIBUS PA basic module

DM = display module

BM = basic module

SM = switching module

HM = HART-module

PDM = Siemens Process Device Manager

AMS = Asset Management Solutions

475 = Emerson Handheld Communicator

# Connection diagram

## Basic module: 4...20mA / PROFIBUS PA

Internal terminals with cable gland design

Circular connector <sup>1</sup>

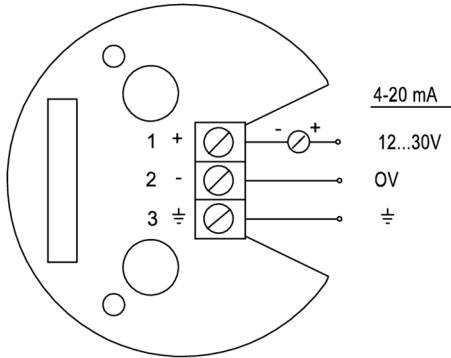

PROFIBUS PA  
9...32V  
0V  
⊥

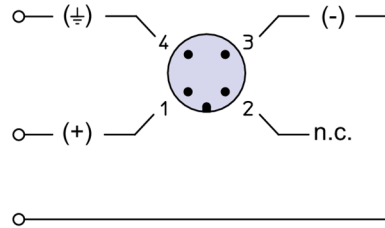

## Switching module: (only with basic module 4...20 mA)

Circular connector <sup>1</sup>

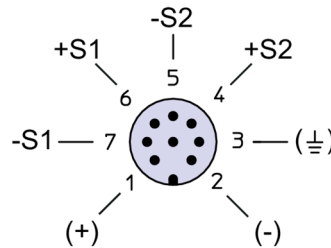
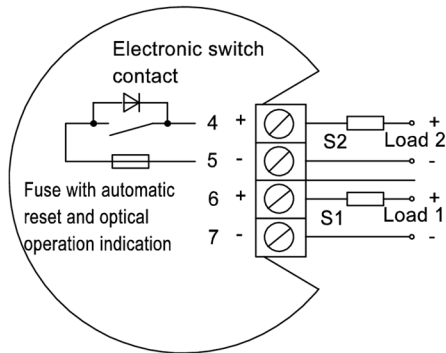

(+) = white  
(-) = brown  
⊥ = green  
(+S2) = yellow  
(-S2) = grey  
(+S1) = pink  
(-S1) = blue

<sup>1</sup> color code as Binder series 763

# Dimensions

## Case

housing design type 17  
-basic module: 4...20 mA  
with one function module (optional)  
-basic module: PROFIBUS PA

housing design type 25  
-basic module: PROFIBUS PA  
with display module (optional)

housing design type 32  
-basic module: 4...20 mA  
with two function modules (optional)

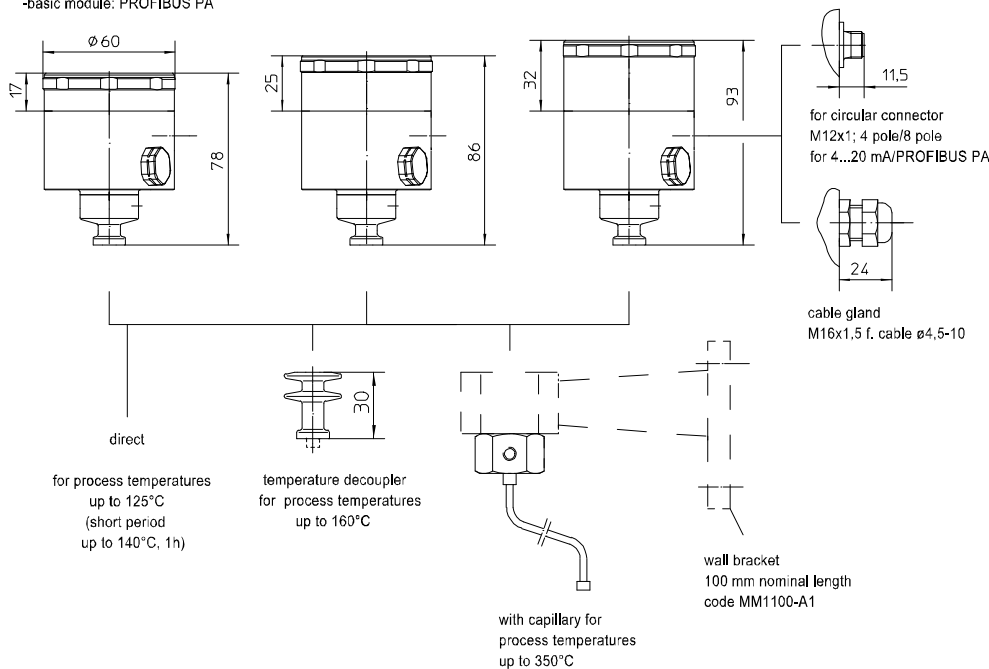

## Process connection

for details see order details  
and relevant data sheets.  
product group D5

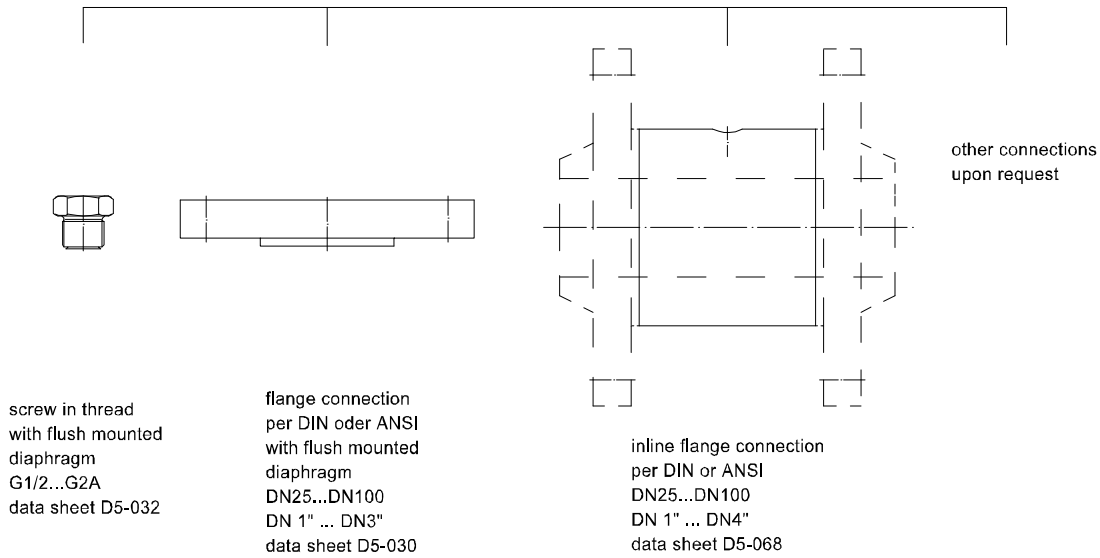

## Mounting position

Mounting position: any

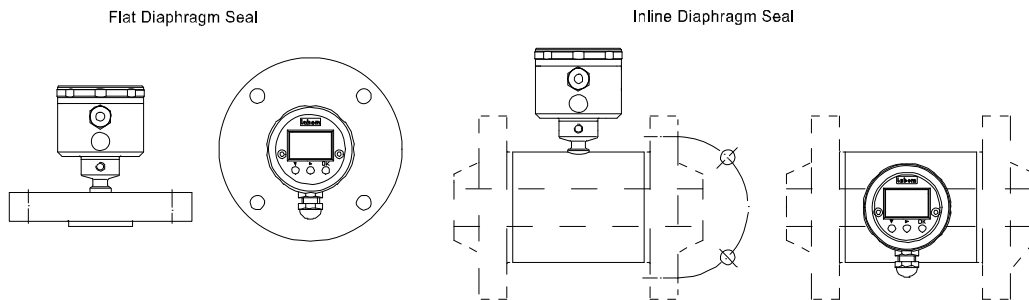

Standard position of display module and electrical connection.  
Please state variant arrangement.







## Order details

### Pressure transmitter PASCAL CV for diaphragm seal operation, robust Type series CV312.-.....-D

Order details PASCAL CV312.-.....-D				
CV312.	Pressure transmitter PASCAL CV for diaphragm seal operation, robust			
0	Ex-protection	without		
1		Ex-protection, type of protection as follows		
		nominal range	overload limit	
A1051	nominal range	0.4 bar	1 bar	
A1053		1 bar	3 bar	
A1056		4 bar	10 bar	
A1059		16 bar	60 bar	
A1061		40 bar	100 bar	
A1063		100 bar	200 bar	
B1056		4 bar abs	10 bar	
B1059		16 bar abs	60 bar	
F10	measuring range	0 to nominal range, unit: bar (standard)		
F11		0 to nominal range, unit: mbar		
F22		0 to nominal range, unit: kPa		
F23		0 to nominal range, unit: MPa		
F30		0 to nominal range, unit: mmH2O		
F32		0 to nominal range, unit: mH2O		
F41		0 to nominal range, unit: kg/cm <sup>2</sup>		
F50		0 to nominal range, unit: PSI		
F80		set from... to... unit ( please fill in details ) not with PROIBUS PA		
F81		adjusted and calibrated from....to....., unit (pls.fill in details), s. below for calibration report		
H11 ..	output signal	4...20 mA, rising characteristic (standard)		
H15 ..		20...4 mA, falling characteristic		
H21 ..		4...20 mA with HART function module, HART protocol rev. 6		
0		setting <sup>1</sup>	damping	0.0 sec. (standard)
1				0.0...120.0 sec., set to ... (please fill in)
0		alarm state		< 3.6 mA (standard)
1				> 21.0 mA
H41		Profibus PA, IEC 61158-2, Profil 3.0		
M1	display module	without		
M2		multifunctional display with 5-position digital display and bar graph, pluggable		
N10	switching module <sup>2,6</sup> (not with PROFIBUS PA) (not with Ex protection)	without switching module		
N5 .		switching module with 2 contacts, pluggable	switching capacity 30 V DC / 0.5 A	
0		setting <sup>1</sup>	standard	
1	at the factory, specify as required			
T30	electrical connection	circular plug connector	M12x1 (4-pin)	
T31			M12x1 (8 pin, required for switching module)	
T20		cable gland M16x1,5	polyamide black	
T21			brass-nickel plated	
T22			stainless steel	
K1085	design	for media temperature up to 125 °C (short term up to 140 °C), standard		
K2085		for media temperature up to 160 °C (with temperature decoupler) <sup>3</sup>		

DE1280	process connection <sup>4</sup>	screw-in connection	G3/4 A		
DE1380			G1 A		
DE1580			G1 1/2 A		
DA1 ...		flange	raised face DIN EN 1092-1 model B1 (DIN 2526 model C/D)		
DA2 ...				raised face B2 (model E), in case of special diaphragm material	
... 120				DIN	DN 25, PN 10/40
... 420					DN 50, PN 10/40
... 620					DN 80, PN 10/40
					further DN/PN upon request
DA51 ...				raised face ASME B16.5 RF500 RMS	
DA5 ...				raised face ASME B16.5 RFSF, in case of special diaphragm material	
... 120				ASME	DN 1" Class 300
... 320					DN 2" Class 300i
... 520		DN 3" Class 300			
		further DN/PN upon request			
DP2180		inline flange connection (cell design)	DIN with plain raised face, model B2	DN 25	
DP2380				DN 40	
DP2480				DN 50	
DP2580				DN 65	
D2680				DN 80	
	further DN/PN upon request				
DP6180	ASME with plain raised face ASME B16.5 RFSF		DN 1"		
DP6280			DN 1 1/2"		
DP6380			DN 2"		
DP6480			DN 2 1/2"		
DP6580			DN 3"		
			further DN/PN upon request		
A4007	material wetted parts	stainless steel mat.-no. 1.4435			
A4002		Tantalum			
A4003		Hastelloy C 276			
A4006		stainless steel material with PTFE foil			
A4001		stainless steel mat.-no. 1.4404/1.4435 (ASTM 316 L)			
L22	system filling	foodstuff oil FD1 (USDA-H1 acc. to FDA) temperature range: -10...+140 °C, standard			
L23		foodstuff oil FD1 (USDA-H1 acc. to FDA) L23 pls. specify temperature range, max. -40...+200 °C			
L31		high temperature oil, temperature range: -10...+350 °C			
		other liquids and temperature ranges upon request			
F1	immersion length L <sup>5</sup>	60 mm standard at ≥ DN 80 (3")			
F2		100 mm standard at ≤ DN 65 (2 1/2")			

Additional features (to be indicated if required)			
S68	Ex marking <sup>2</sup>	ATEX	 II 2 G Ex ia IIC T4/T5/T6 Gb, II 2 D Ex ia IIIC Txx°C Db
S66			 II 1/2 G Ex ia IIC T4/T5/T6 Ga/Gb
S88		UKEX	 II 2 G Ex ia IIC T4/T5/T6 Gb, II 2 D Ex ia IIIC Txx°C Db
S86			 II 1/2 G Ex ia IIC T4/T5/T6 Ga/Gb
T4	degree of protection	IP 69K	
Z61	PROFIBUS PA	factory setting standard, pls specify	
Z62		measuring-point number/identification max. 32 characters, pls. specif	
Z63		measuring-point text max. 32 characters, pls. specify	
W1020	material certificate as per EN 10204-3.1, wetted parts (stainless steel)		
W1201	calibration certificate as per EN 10204- 3.1, 5 measuring points		
W2602	functional safety as per EN 61508, classification per SIL2 <sup>6</sup>		
W2660	as per UKCA regulations <sup>7</sup>		

Order code (example): CV3120 - A1051 - F11- H1100 - M2 - N10 - T20 - K1085 - DE1280 - A4001 - L22 - ...

<sup>1</sup> settings see parameterisation

<sup>2</sup> Ex-design not possible with switching module

<sup>3</sup> higher temperatures upon request

<sup>4</sup> further process connections upon request

<sup>5</sup> necessary for inline diaphragm seals (cell design) only

<sup>6</sup> not with PROFIBUS PA

<sup>6</sup> not possible with inline diaphragm seals