

Pressure transmitter PASCAL CV4

for diaphragm seal operation

Type series CV4110



Application area

- Pharmaceutical industry
- Food industry
- Biotechnology
- General process technology

Features

- Compact case of stainless steel in hygienic design according to recommendations from EHEDG and 3A, degree of protection IP 65/67
- Accuracy $\leq 0.15\%$
- High-resolution graphic display with intuitive operation and backlight
- Quick access to device data
- Comprehensive parameterisation, simulation and diagnostic functions
- Nominal range 0.25 bar to 100 bar
- Turndown up to 20:1
- Output signal 4...20 mA with HART®-protocol
- Digital communication via PDM/EDD and FDT/DTM
- Output functions: linear, inverse
- Table function with up to 32 support points
- Wetted parts stainless steel
- Case design:
 - process connection at back
 - process connection bottom
- Various hygienic process connections, selected connections with EHEDG certificate

Options

- Labom REconnect quick coupling device for easy and safe separation and connection of diaphragm seal systems; Type series MK1000, see data sheet DB_D6-022
- Accuracy $\leq 0.1\%$
- Approvals/Certificates
 - Explosion protection (ATEX/IECEx/UKEX) for gases and dust
 - UL 61010-1 and CAN/CSA-C22.2 no. 61010-1
 - Material certificate per EN 10204-3.1
 - Calibration certificate per EN 10204-3.1
- As per UKCA regulations
- Degree of protection IP 69K
- Case and front cover of stainless steel 316L
- Wetted parts electropolished

Application

The digital pressure transmitter PASCAL CV4 is suitable for measuring the relative and absolute pressure of gases, vapors and liquids. Due to the design and various process connections, the transmitter is suitable for the hygienic requirements of the food and pharmaceutical industry.

Technical data

Measuring ranges

Up to a turndown of 20:1 the measuring span can be freely selected.

Nominal range	Measuring span		Overload capacity	Lower measuring range limit **
	min.	max.		
0...1 bar *	0.05 bar	2 bar	3 bar	100 mbar abs
0...4 bar *	0.2 bar	5 bar	10 bar	100 mbar abs
0...16 bar *	0.8 bar	17 bar	60 bar	100 mbar abs
0...40 bar *	2.0 bar	41 bar	100 bar	100 mbar abs
0...100 bar *	5.0 bar	101 bar	200 bar	100 mbar abs
-0.25...0.25 bar	0.0125 bar	0,5 bar	1 bar	750 mbar abs
-1...1 bar	0.05 bar	2 bar	3 bar	30 mbar abs
-1...4 bar	0.2 bar	5 bar	10 bar	30 mbar abs
-1...16 bar	0.8 bar	17 bar	60 bar	30 mbar abs
-1...40 bar	2.0 bar	41 bar	100 bar	30 mbar abs
-1...100 bar	5.0 bar	101 bar	200 bar	30 mbar abs
0...1 bar abs	0.05 bar abs	1 bar abs	3 bar abs	30 mbar abs
0...4 bar abs	0.2 bar abs	4 bar abs	10 bar abs	30 mbar abs
0...16 bar abs	0.8 bar abs	16 bar abs	60 bar abs	30 mbar abs
0...40 bar abs	2.0 bar abs	40 bar abs	120 bar abs	30 mbar abs

* Short term or sporadic measurement in vacuum range permitted up to lower measuring limit. Lower range value up to -1 bar rel. adjustable.

** Vacuum-proof designs are available upon request. Lower measuring range limit for FB Clamp DN 38 is 250 mbar abs.

Constructional design / case

Design: Hygienic case of stainless steel, continuously rotatable by $\pm 170^\circ$

Material case and front cover: Process connection back:
Stainless steel mat.-no. 1.4305 (303)
Option: stainless steel mat.-no. 1.4404 (316L)
Process connection bottom:
Stainless steel mat.-no. 1.4301 (304)
Option: stainless steel mat.-no. 1.4404 (316L)

Gasket: Silicone
EPDM / FKM (if degree of protection IP 69K)

Degree of protection per EN 60529: IP 65 / IP 67
Option: IP 69K

Climatic category: 4K4H per EN 60721 3-4

Material window: Macrolon hardened
Option: Non-splintering glass

Electrical connection: Circular connector M12
Option: Cable glands

- M16 x 1.5, PA black
- M16 x 1.5, brass nickel-plated
- M16 x 1.5, stainless steel
- M20 x 1.5, PA black
- M20 x 1.5, brass nickel-plated
- M20 x 1.5, stainless steel
- 1/2" NPT, PA black

Further connections upon request

Terminal blocks: Spring clamp terminals up to 2 mm²

Type plate: Adhesive label

Process connection

Position: ■ back
■ bottom

Design: See order details

Material wetted parts

Material: See order details

Hygienic design

The surface roughness of the wetted parts made of stainless steel are executed according to EHEDG Doc.8 and ASME BPE SF3.
In case of choosing the additional feature HY, we guarantee the following surface roughness values:

Diaphragm foil: Ra $\leq 0.38 \mu\text{m}$

Laser welds: Ra $\leq 0.76 \mu\text{m}$

Turned parts: Ra $\leq 0.76 \mu\text{m}$

Further versions of hygienic design upon request.

Measuring system

Sensor: Piezoresistive measuring element

System filling: Synthetic oil FD1, free of silicone, FDA compliant

Accuracy

Reference cond. per EN 61298-1:	$T_U = \text{const. (15...25) } ^\circ\text{C}$ $\varphi = \text{const. (45...75) \% r.F.}$ $p_U = \text{const. (860...1060) mbar}$ $U_B = 24 \text{ V DC } (\pm 3 \text{ V DC})$ $R_B = 50 \text{ } \Omega, \text{ HART: } 250 \text{ } \Omega$ Ground connected Lower range value = 0 bar
Calibration position:	vertical
Deviation of characteristic:	Refer to the adjusted measuring span (Limit point method per DIN 16086) Up to Turndown 5:1 $\leq \pm 0.5 \%$ Turndown > 5:1 $\leq \pm 0.03 \%$ x TD Option (not for NR 250 mbar) Up to Turndown 5:1 $\leq \pm 0.1 \%$ Turndown > 5:1 $\leq \pm 0.02 \%$ x TD
Long-term drift:	Refer to nominal range $\leq 0.1 \%$ /year
Temperature influence case:	Refer to nominal range Ambient temperature $-20...80 \text{ } ^\circ\text{C}$: 0.15% /10K, max. 0.4% Ambient temperature $-40...-20 \text{ } ^\circ\text{C}$: Typical $\pm 0.2 \%$ /10K
Temperature influence process connection:	Depending on type of diaphragm seal. Detailed error analysis upon request.

Indication

Display:	<ul style="list-style-type: none">- High-resolution graphic display with backlight- 4-button operation- Freely configurable display modes- Continuously rotatable- Removable under voltage
----------	----------------------------------------------------------------------------------------------------------------------------------------------------------------------------------------------------------------------------------------------

Output

Signal:	2-wire technology	4...20 mA
	Lower limit	3.8...4 mA
	Upper limit	20...21 mA
	Lower alarm current	< 3.6 mA
	Upper alarm current	> 21 mA
	Current limitation	22 mA
	Digital communication:	HART [®] -protocol, version 7
Device driver:	<ul style="list-style-type: none">■ EDD for SIMATIC PDM■ DTM for PACTware or compatible systems (FDT compliance)	

Function:	<ul style="list-style-type: none">■ Linear■ Invers■ Table function with up to 32 support points
Turndown:	Up to 20:1
Damping:	0...999.9 s
Measuring rate:	20 Hz
Resolution:	$\leq 1 \text{ } \mu\text{A}$
Current sensing func.:	3.55...21.5 mA selectable in steps of 0.001 mA
Load R_B :	$R_B \leq (U_V - 12 \text{ V DC}) / 0.022 \text{ A } [\Omega]$ $U_V = \text{supply voltage}$ for HART [®] communication $R_B \geq 230 \text{ } \Omega$

Supply voltage

Functional range:	12...30 V DC, protected against polarity reversal For Ex design: 13...30 V DC, protected against polarity reversal For UL/CSA: 12...30 V DC, protected against polarity reversal, PELV Further informations see Operating Instruction BA_080.
Ripple:	< 5 %

Temperature ranges

Ambient:	$-20...80 \text{ } ^\circ\text{C}$ Option: $-40...80 \text{ } ^\circ\text{C}$ (Display visibility is limited at temperatures below $-30 \text{ } ^\circ\text{C}$) For UL/CSA: $5...40 \text{ } ^\circ\text{C}$
Media:	$-10...140 \text{ } ^\circ\text{C}$ at $T_u \leq 70 \text{ } ^\circ\text{C}$, $P > 400 \text{ mbar abs}$ $T_u = \text{ambient temperature}$ Option: $-20...160 \text{ } ^\circ\text{C}$ at $T_u \leq 70 \text{ } ^\circ\text{C}$, $P > 500 \text{ mbar abs}$ $T_u = \text{ambient temperature}$ <u>Vacuum application:</u> $10...500 \text{ mbar abs: } -20...120 \text{ } ^\circ\text{C}$ < 10 mbar abs upon request
Storage:	$-40...80 \text{ } ^\circ\text{C}$

Ambient conditions for UL/CSA

- Exclusively for indoor use
- Altitude up to 2000 m
- Maximum relative humidity 80 % for temperatures up to 31 °C, decreasing linearly to 50 % relative humidity at 40 °C
- Pollution degree 2

Tests and certificates

Ex approvals

ATEX:	TÜV 20 ATEX 265286 X ⊕ II 1/2G Ex ia IIC TX Ga/Gb ⊕ II 1/2D Ex ia IIIC Txx °C Da/Db ⊕ II 2G Ex ia IIC TX Gb ⊕ II 2D Ex ia IIIC Txx °C Db
IECEX:	IECEX TUN 20.0015X Ex ia IIC TX Ga/Gb Ex ia IIIC Txx °C Da/Db Ex ia IIC TX Gb Ex ia IIIC Txx °C Db
UKEX:	CML 21UKEX21177X ⊕ II 1/2G Ex ia IIC TX Ga/Gb ⊕ II 1/2D Ex ia IIIC Txx °C Da/Db ⊕ II 2G Ex ia IIC TX Gb ⊕ II 2D Ex ia IIIC Txx °C Db

For detailed information see Ex Instruction XA_027.

UL/CSA :	per UL 61010-1 and CAN/CSA-C22.2 no. 61010-1 UL certificate no. E536236
EMV :	Per EN 61326-1

Parameterisation, simulation and adjustment

Parameterisation

Parameter	Values	Default setting
Device		
device ID	16 digits, freely selectable	ID: PASCAL CV4
damping	0,0...999.9 s	0.0 s
Display and control unit		
pressure unit	mbar, bar, Pa, hPa, kPa, MPa, g/cm ² , kg/cm ² , psi, atm, torr, mmH ₂ O, mH ₂ O, inH ₂ O, ftH ₂ O, mmHg, inHg	bar
temperature unit	°C, °F, °R, K	°C
lighting	on, off	on
language	English, German, Chinese	German
decimal point	auto, x.xxxx, xx.xxx, xxx.xx, xxxx.x, xxxxx	auto
display mode	four values, three values, two values, big display,	three values
main value	pressure, current (%), current (mA)	pressure
secondary values	pressure, current (%), current (mA), sensor temperature, device ID, HART-TAG, HART descriptor, <empty>	device ID , Bargraph
Current output		
output function	linear, invers, table	linear
number of table points	2...32	2 (0 % ≙ 4 mA, 100 % ≙ 20 mA)
lower range value	at any value within nominal range	0 bar
upper range value	at any value within nominal range	upper range limit
lower current limit	3,8...4,0 mA	3,8 mA
upper current limit	20...21 mA	20,5 mA
alarm current	low (<3.6 mA), high (> 21.0 mA)	low (<3.6 mA)
position correction	on, off	off
HART® data		
HART® address	0...63	0
number of response preambels	5...20	5
current mode	proportional, constant	proportional

Diagnostic functions

Measuring circuit diagnostics	Description	Value
loop-test	setting of a fixed current value at the output	3.55...21.5 mA
pressure simulation	setting a fixed pressure value, it also considers damping and tabular function unlike the current simulation	nominal range
min/max values	for process pressure and sensor temperature	/

Adjustment

Type	Description
zero point correction	adjusts reading to zero at ambient pressure (for differential and gauge pressure devices)
position correction	adjusts reading of mounted device to zero at ambient pressure (only relative pressure measurement devices)
lower adjustment	adjusts reading of mounted device to zero at ambient pressure
upper adjustment	adjusts reading to applied pressure (affects span only)
current adjustment	adjusts current output to achieve 4 resp. 20 mA at the end of the measurement chain

Parameterisation for devices without a firmly fitted display

Parameterisation possible via HART® protocol.

Parameterisation possible at any time via plugging a display module.

Connection diagram

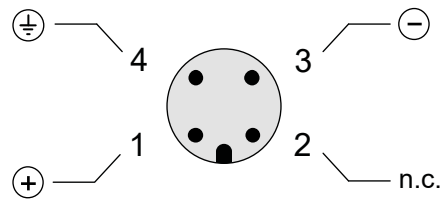
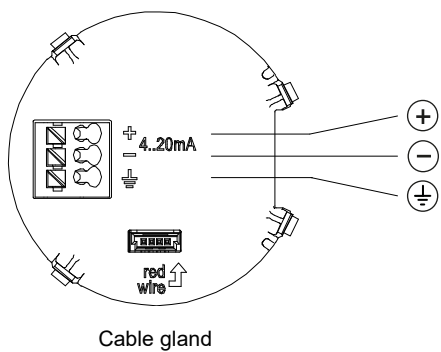

Dimensions

Standard Case

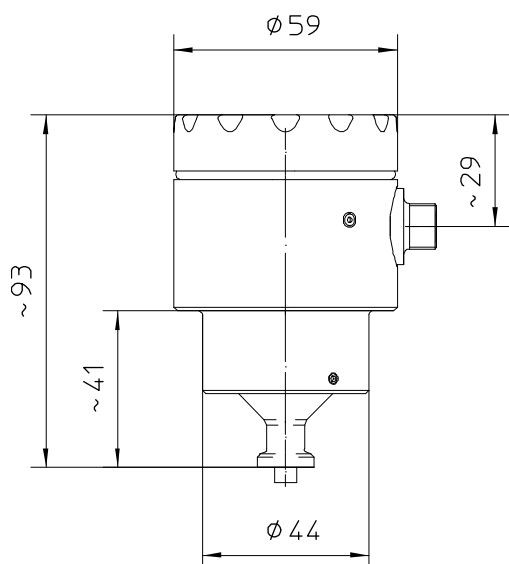

process connection at back

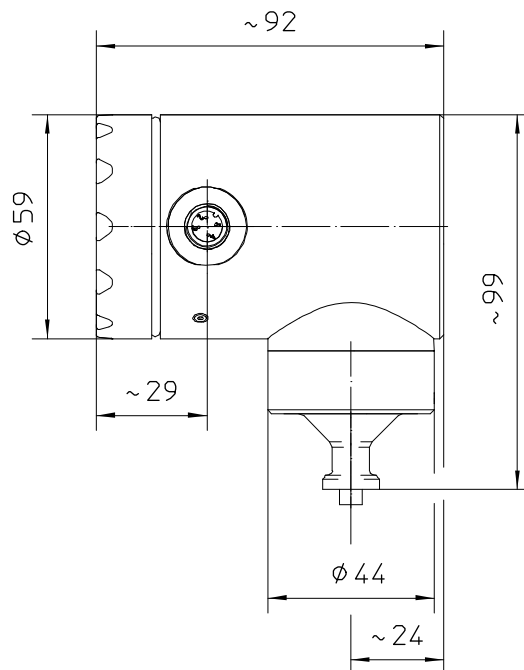

process connection bottom

Case in Ex design

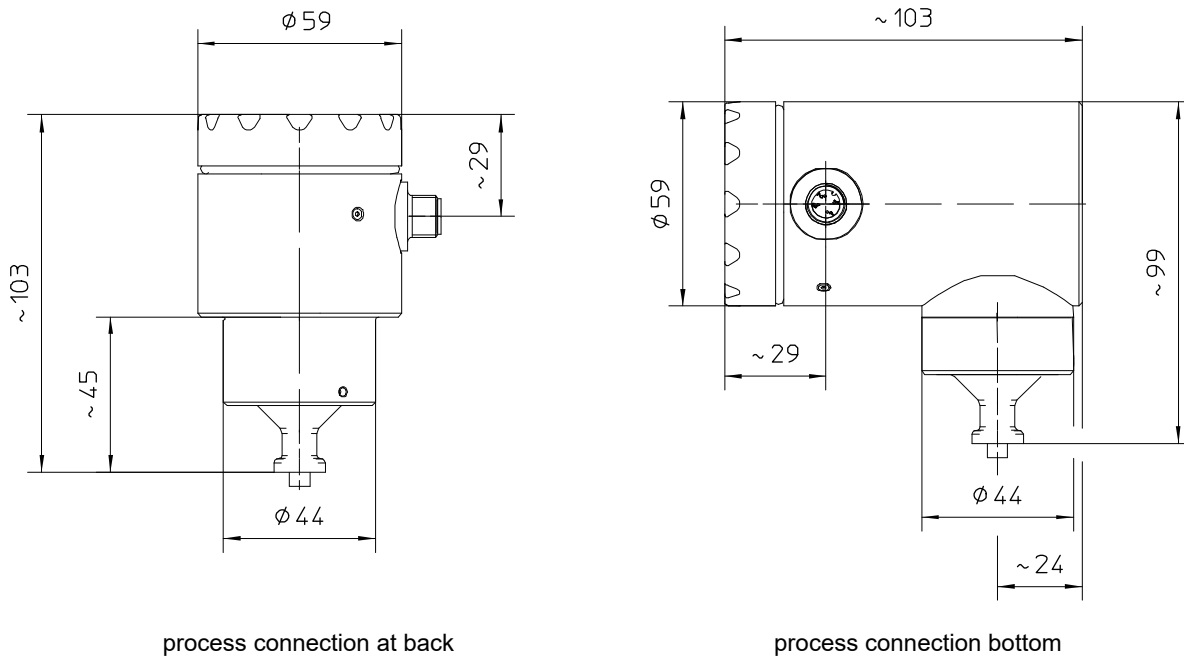

process connection at back

process connection bottom

Electrical connection

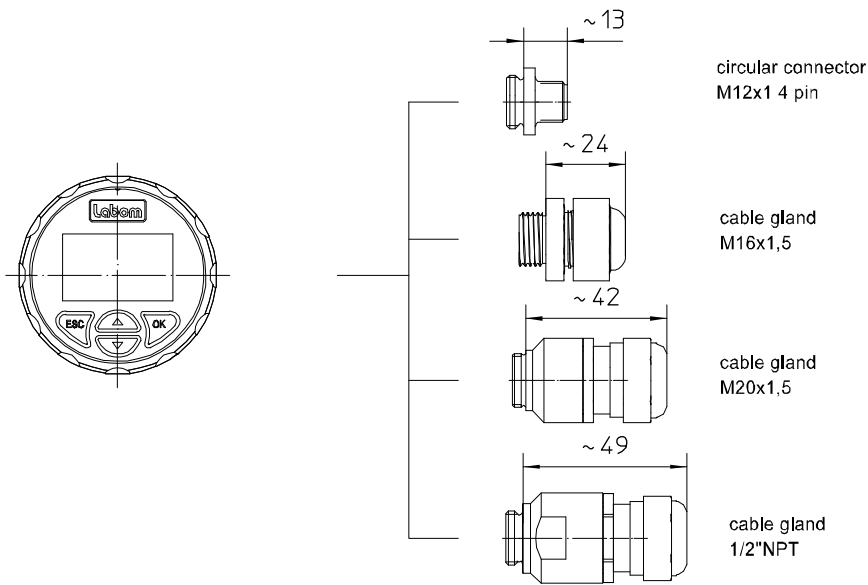

All dimensions are in mm

Process connection

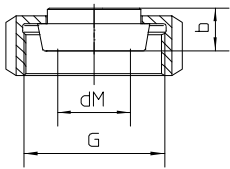

sanitary connection
with coupling nut
per DIN 11851

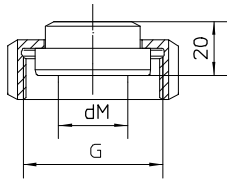

aseptic screw joint
collar connection
with union nut per
DIN 11864-1

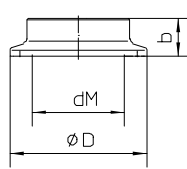

clamp connection
per DIN 32676/ISO 2852

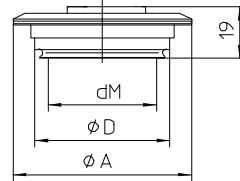

VARIVENT® connection for
VARINLINE® case

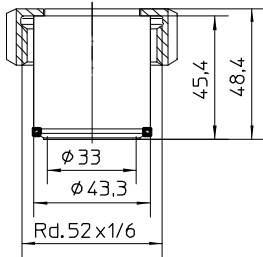

HYGENIC-Tubus *
Ø43.3 with screwing
DN25/PN40

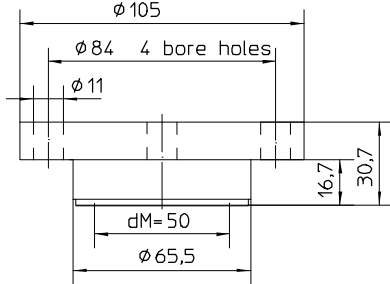

DRD-connection DN50 PN40 *

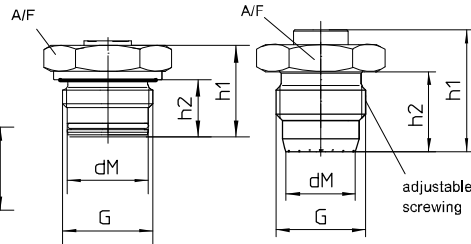

Screw-in thread *
with o-ring-gasket
and additionally gasket
per DIN EN ISO 1179-2
model E (DIN 3852)

HYGENIC-screw-in thread *
no gasket
tightening torque
20 Nm, max. nominal pressure 10 bar
50 Nm, max. nominal pressure 50 bar

* weld-in adapter
see data-sheet D6-037

All dimensions are in mm

Sanitary pipe connection with union nut per DIN 11851

DN	PN	dM	b	G
25	40	27	16	Rd.52x1/6"
32	40	34	16	Rd.58x1/6"
40	40	40	16	Rd.65x1/6"
50	25	51	17	Rd.78x1/6"

Aseptic screw joint collar connection with union nut per DIN 11864-1

DN	PN	dM	G
25	40	24	Rd.52x1/6"
32	40	30	Rd.58x1/6"
40	40	34	Rd.65x1/6"
50	25	48	Rd.78x1/6"

Clamp connection per DIN 32676 model A (metric) for pipes per EN 10357 (DIN 11850)

DN	PN	dM	b	D
25	25	22.6	14	50.5
32	25	27	12	50.5
40	25	34	12	50.5
50	16	46	14	64

Clamp connection per DIN 32676 model B (OD, ISO) for pipes per DIN EN ISO 1127

DN	PN	dM	b	D
26.9	25	22.6	14	50.5
33.7	25	27	12	50.5
42.4	25	34	12	64
48.3	16	40	14	64

Clamp connection per DIN 32676 model C (Tri-Clamp) for pipes per ASME BPE

DN	PN	dM	b	D
3/4"	25	15.5	15	25
1"	25	22.6	14	50.5
1 1/2"	25	34	12	50.5
2"	16	46	14	64

Clamp connection per ISO 2852 for pipes per ISO 2037

DN	PN	dM	b	D
25	16	22.6	14	50.5
38	16	34	12	50.5
51	16	46	14	64

VARIVENT® connection for VARINLINE® access unit

Connection	PN	dM	A	D
Form F	25	40	66	50
Form N	25	58	84	68

HYGIENIC screw-in thread, gasket without elastomer

G	PN (bar)	dM	h1	h2	SW
G1 A	50	24	45	28.5	36





Screw-in thread with O ring gasket

G	PN (bar)	dM	h1	h2	SW
G1/2 A	200	15.5	33	20.5	27
G1 A	50	24	33	20.5	41

Order details

Pressure transmitter PASCAL CV4 for diaphragm seal operation			
CV4110	pressure transmitter PASCAL CV4 for diaphragm seal operation		
R70	position process connection	at back	
R71		bottom	
	nominal range	overload limit [bar]	
A1053	0...1 bar	3	
A1056	0...4 bar	10	
A1059	0...16 bar	60	
A1061	0...40 bar	100	
A1063	0...100 bar	200	
A1178	-0.25...0.25 bar	1	
A1153	-1...1 bar	3	
A1156	-1...4 bar	10	
A1159	-1...16 bar	60	
A1161	-1...40 bar	100	
A1163	-1...100 bar	200	
B1053	0...1 bar abs	3	
B1056	0...4 bar abs	10	
B1059	0...16 bar abs	60	
B1061	0...40 bar abs	120	
F1	parameterisation	standard according to data sheet (see parameterisation table)	
F9		as per customer's specification	
Q2	accuracy	≤ 0.15 %	
Q1		≤ 0.1 % ¹	
H21	output signal	4...20 mA, with HART®-protocol	
Y14	material case/window	stainless steel mat.-no.1.4305 (303)	window Macrolon
Y15			window Macrolon, UL case design
Y12			window non-splintering glass
Y13			closed, without window
Y24		stainless steel mat.-no.1.4404 (316L)	window Macrolon
Y25			window Macrolon, UL case design
Y22			window non-splintering glass
Y23			closed, without window
T1	case degree of protection	IP 65 / IP 67	
T4		IP 69K ²	
			default language
M21.1	display	High-resolution graphic display with backlight, intuitive 4-button operation, quick access to device data	English
M21.2			German
M21.3			Chinese
M1		without display	
T20	electrical connection	cable gland	M16 x 1.5 polyamide, for cable Ø 4.5-10 ³
T21			M16 x 1,5 brass nickel-plated, for cable Ø 5-10
T22			M16 x 1.5 stainless steel, for cable Ø 5-9 ³
T15			M20 x 1.5 polyamide, for cable Ø 7-13 ³
T16			M20 x 1,5 brass nickel-plated, for cable Ø 7-13
T17			M20 x 1.5 stainless steel, for cable Ø 8-13 ⁴
T27			1/2" NPT PA for cable Ø 5-12 mm ⁵
T30			circular connector M12 x 1 (4 pin) ³

Continuation order details PASCAL CV4110			
K102	process connection material: ASTM 316L	sanitary pipe connection with union nut per DIN 11851 ^{6,7}	DN 25
K103			DN 32
K104			DN 40
K105			DN 50
K162			aseptic screw joint collar connection with union nut per DIN 11864-1 ⁶
K163		DN 32	
K165		DN 40	
K166		DN 50	
K124		clamp connection per ISO 2852 for pipes per ISO 2037 ^{6,7}	DN 25 (1")
K126			DN 38 (1 1/2")
K127			DN 51 (2")
K144		clamp connection per DIN 32676, model A (metric) for pipes per EN 10357 (DIN 11850) ^{6,7}	DN 25
K146			DN 32
K147			DN 40
K148			DN 50
K213			clamp connection per DIN 32676, model B (OD, ISO) for pipes per DIN EN ISO 1127 ^{6,7}
K214		DN 33,7	
K215		DN 42,4	
K216		DN 48,3	
K134		clamp connection per DIN 32676, model C (Tri-Clamp) for pipes per ASME BPE ^{6,7}	DN 3/4"
K136			DN 1"
K137			DN 1 1/2"
K138			DN 2"
K152		VARIVENT® connection ^{6,7}	Form F (D=50) for VARINLINE® access unit
K153			Form N (D=68) for VARINLINE® access unit
K172		HYGIENIC tubus	Ø 43,3 mm with screwing DN 25/PN 40
K185		DRD connection	nominal width DN 50 / nominal pressure PN 40
K194		screw-in thread	G 1/2 A with O-ring seal
K195			G 1 A with O-ring seal
K80			G 1 A with hygienic process connection (elastomer-free)
P1	media temperature	-10...140 °C	
P9		variants as in writing	
U1	ambient temperature	-20...80 °C ⁴	
U7		-40...80 °C ⁴	
U12		5...40 °C	

Additional features (to be indicated if required)			
HY	surface roughness (wetted parts)	Hygienic version as per EHEDG Doc. 8 and ASME BPE SF3	
S66	Ex marking ⁸	ATEX	 II 1/2G, II 2G Ex ia IIC TX Ga/Gb, Gb
			 II 1/2D, II 2D Ex ia IIIC Txx°C Da/Db, Db
IECEX		Ex ia IIC TX Ga/Gb, Gb	
		Ex ia IIIC Txx°C Da/Db, Db	
S86	UKEX	 II 1/2G, II 2G Ex ia IIC TX Ga/Gb, Gb	
		 II 1/2D, II 2D Ex ia IIIC Txx°C Da/Db, Db	
W1020	material certificate	per EN 10204-3.1, wetted parts	
W1201	calibration certificate	per EN 10204-3.1, 5 measuring points	
W2660	as per UKCA regulations		
W2680	approval per UL 61010-1 and CAN/CSA-C22.2 no. 61010-1 ^{9,10}		

Order code example: CV4110 – A1056 – F1 – Q2 - H21 – Y14 – T1 - M21.2 - T20 – K102 - P1 - U1

¹ not for nominal range 0.25 bar

² only possible with window of Macrolon, gasket made of EPDM/FKM and selected electrical connections (see footnote 3)

³ suitable for degree of protection IP 69K

⁴ not possible for UL/CSA

⁵ for UL/CSA upon request

⁶ EHEDG certified only in connection with hygienic design (order code option HY)

⁷ EHEDG certificate valid only if gaskets are used that are listed in the "EHEDG position paper"

⁸ not possible with window of Macrolon, not suitable for degree of protection IP 69K

⁹ not possible for devices with Ex marking

¹⁰ only in combination with UL/CSA case design (order code Y15 or Y25) or with closed case without window (order code Y13 and Y23) and at a fixed ambient temperature (order code U12)