

## Pressure switch with bourdon tube for plants requiring special supervision Type series BN4...



### Application area

- General process technology
- Chemical and petrochemical industry
- Machinery construction
- Shipping

### Features

- Pressure switch with bourdon tube for plants requiring special supervision,
- Nominal ranges -1...0 bar to -1...24 bar, 0...1 to 0...400 bar
- High quality case with bajonet ring NS 100 per EN 837-1 S1, alternative safety design per EN 837-1 S3
- Ex-proof design
- Case and measuring element of stainless steel
- Accuracy class as per DIN 16085
- Inductive contact

### Options

- Approvals/Certificates
  - Classification per SIL2
  - Material certificate per EN 10204-3.1
  - Calibration certificate per EN 10204-3.1
- Case with liquid filling
- Oxygen free of oil and grease
- Connection to Zone 0 by using the flame arrester MF21xx, see data sheet DB\_D6-025

### Application

Pressure switches with bourdon tubes are pieces of equipment with safety functions as set down in the Pressure Equipment Directive (PED). They are suitable for protecting the pressure device should the pressure rise above, or drop below, the approved boundary limits. They come under the remit of PED 1G Category IV and have been subjected to an EC type-examination. The requirements of Approval Certificate Pressure 100 from the German Technical Inspection Authority (VdTÜV) are met. These pressure measuring devices may only be operated with the electrical evaluation units set out below, and within the area of application of this certificate and the VdTÜV component identification number. The pressure switch is composed of the pressure measuring device and electrical evaluation unit. Because of its robust design, it is suitable for use in tough environments.

## Technical data

### Constructional design / case

Design:	High quality case with bayonet ring per EN 837-1 S1, material: stainless steel mat.-no.-1.4301 (304) ; with blow-out device, material: PUR, ventilation valve, material: PUR
	Alternative: Safety design with blow-out back and solid baffle wall per EN 837-1 S3, Material: Stainless steel 1.4301 (304)
Nominal size:	NS 100
Degree of protection per EN 60529:	<ul style="list-style-type: none"> <li>■ Without filling: IP 65</li> <li>■ With filling S1 case: IP 65</li> <li>■ With filling S3 case: IP 66</li> </ul>
Case filling:	Labofin
Atmosph. pressure compensation:	Via ventilation valve. Safety case, filled: with pressure compensation diaphragm, material: silicone
Case seal:	Material gasket: NBR
Window:	Non splintering laminated glass
Contact lock:	Stainless steel with NBR gasket, sealable
Measuring element:	Bourdon tube  < 60 bar: c-type ≥ 60 bar: spiral
Movement:	Stainless steel segment
Scale:	Pure aluminium, white with black inscription
Pointer:	Pure aluminium, black, with micro adjustment for zero point correction
Mounting:	Via process connection. Optional with flange for surface mounting or for flush mounting with DIN mounting flange.
Electronical connection:	Connection plug with cable gland M20 x 1.5 and removable test cover, material: Macrolon
Electrical evaluation unit:	The following evaluation units conform to the requirements of the Association of Technical Inspection Agencies (VdTÜV) Fact Sheet No. 100. Pepperl+Fuchs, switching amplifier: <ul style="list-style-type: none"> <li>■ Typ KHA6-SH-Ex1, PTB 00 ATEX 2043</li> <li>■ Typ KFD2-SH-Ex1, PTB 00 ATEX 2042</li> </ul> <p>The use of alternative evaluation units is within the responsibility of the operator. The data sheets of the electrical evaluation units are to be observed.</p>

Weight:	NS 100 without filling:	approx. 0.9 kg
	NS 160 without filling:	approx. 1.8 kg
	NS 100 with filling:	approx. 1.5 kg
	NS 160 with filling:	approx. 3.6 kg

### Process connection

Design:	Per EN 837-1. G1/2 B, 1/2" NPT or M20 x 1.5, bottom or back eccentric connection.  Optional with throttle screw for system damping, further process connections upon request
---------	---

### Material wetted parts

Measuring element:	Bourdon tube and shanks stainless steel mat.-no. 1.4571 / 1.4404 (316Ti / 316L)
--------------------	---

### Nominal range

See order details, further ranges upon request

Overload-protection:	Standard: 1.3 times nominal range 0...400 bar: 1.1 times
----------------------	---

### Measuring accuracy

Nominal range	Accuracy class:	
	1 contact	2 contacts
1 bar	class 1	class 1.6
≥ 1.6 bar	class 1	class 1

Plus effect of switch function on indication per DIN 16085.

Temperature influence:	Max. ± 0.4% / 10K of measuring span per EN 837-1
------------------------	--

### Temperature ranges

	without filling	with filling
Ambient:	-20...70 °C	-20...70 °C (40 °C) <sup>1</sup>
Media:	-20...70 °C	-20...70 °C (40 °C) <sup>1</sup>
Storage:	-40...70 °C	-20...70 °C

<sup>1</sup> For safety case S3 design (IP 66) and classification per SIL2

## Tests and certificates

Ex-protection: Inductive contact device:  
Contact device suitable for intrinsically safe circuits.

 II 2G Ex ia IIC T4/T5/T6 Gb

Reg.-no.: PTB 00 ATEX 2049X

Ex-protection (ATEX) for mechanical devices:

 II 2G Ex h IIC T1...T6 Gb X

 II 2D Ex h IIC Txx°C Db X

Further details see operating instruction BA\_037 and Ex Instructions XA\_005 and XA\_013.

SIL 2: Functional safety:  
per EN 61508, classification per SIL 2,  
TÜV-Reg.-Nr. 44 799 13190203.

EU Type Examination: Per Directive 2014/68/EU  
Certificate no.:  
0045/202/1201/Z/00637/23/D/001(00)  
Piece of equipment with safety function  
cat. IV VdTÜV-component identification  
number:

- TÜV.SDW.14-234
- TÜV.SDWF.14-234
- TÜV.SDWFS.14-234

## Switch contacts

Inductive contact: Type N4  
(SN)

- Safety initiator
- max. 2 contacts, contactless
- Control unit required

Further information see operating instruction BA\_037.

Inductive contact inverse: Type N5  
(S1N)

- Safety initiator, inverse switching
- max. 2 contacts, contactless
- Control unit required

Further information see operating instruction BA\_037 and Technical Information TA\_039.

## Dimensions

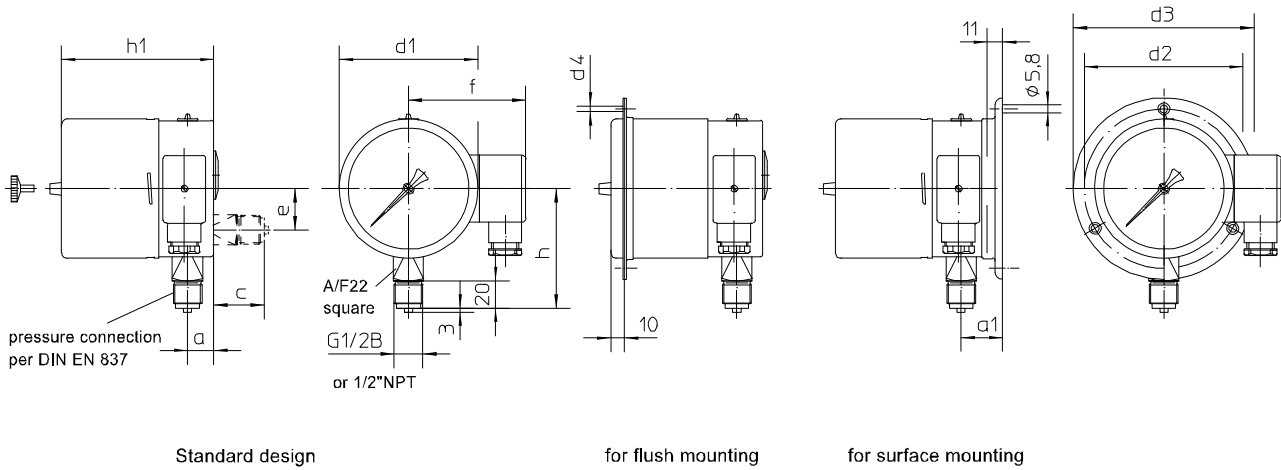

dimension standard design (mm)

	d1	h1	a	c	e	f	h	d2	d3	d4	a1
NS 100	100	111	19	37	30	89	83	116	132	4.8	30

dimensions safety case (mm)

	d1	h1	a	c	e	f	h	d2	d3	d4	a1
NS 100	100	123	37	-	-	89	83	116	132	4.8	-

### Contact settings:

The contacts can be adjusted over the entire indicating range. The black scale section may only be used for pressure-limiting applications. Adjustment is carried out by pressing in, and rotating the internal adjusting finger, using the accompanying adjusting key at the adjustment lock.

### Signal evaluation:

The fitted inductive proximity switches are suitable for connection to switch units with normalized input, according to DIN 19234.

## Order details

Pressure switch with bourdon tube for plants requiring special supervision			
BN4200	standard case IP 65	without liquid filling	process connection bottom
BN4210			process connection back
BN4220		with liquid filling	process connection bottom
BN4230			process connection back
BN4500	safety case IP 65, per EN 873-1 S3	without liquid filling	process connection bottom
BN4540	safety case IP 66, per EN 873-1 S3	with liquid filling	process connection bottom
A2...	process connection	G1/2 B	
B2...		1/2" NPT	
C2...		M20 x 1,5	
086	nominal range [bar]	-1...0 <sup>1</sup>	
087		-1...0.6 <sup>1</sup>	
088		-1...1.5	
089		-1...3	
090		-1...5	
091		-1...9	
092		-1...15	
093		-1...24	
053		0...1	
054		0...1.6	
055		0...2.5	
056		0...4	
057		0...6	
058		0...10	
059		0...16	
060		0...25	
061		0...40	
062		0...60	
063		0...100	
064		0...160	
065	0...250		
066	0...400		
	switch contacts	type of contact	number
N4 . 00	inductive contact	safety-initiator (SN)	single contact
N4 . . 0			double contact
N5 . 00		safety-initiator-inverse (S1N)	single contact
N5 . . 0			double contact
...	<b>switch function - per contact, replace point with number</b>		
2	switch	rising measured value opens contact	
5		falling measured value opens contact	
Additional features (to be indicated if required)			
V2	mounting	rear flange for surface mounting <sup>2</sup>	
V3		front flange for flush mounting	
W2603	functional safety per EN 61508, classification per SIL2		
W4001	free of oil and grease for oxygen application		

### Example of order code switch contacts N4250:

Double inductive contact with initiator → type of contact = N4

1. Inductive contact opens on rising measured value → code number 2
2. Inductive contact opens on falling measured value → code number 5

Additional features (to be indicated if required)			
V2	mounting	rear flange for surface mounting <sup>2</sup>	
V3		front flange for flush mounting	
W2603	functional safety per EN 61508, classification per SIL2		
W4001	free of oil and grease for oxygen application		

Order code (example): BN4200 – A2056 – N4250 - ..

<sup>1</sup> not with case filling

<sup>2</sup> standard case, only