



### Features

- Microprocessor-controlled 2-wire pressure transmitter
- Text-oriented operating control via graphic display
- Parameterization on the transmitter or optional with a HART protocol
- Turndown 20:1
- Measuring ranges 16 mbar to 400 bar
- Accuracy 0.2 %
- Output signal: 4..20 mA, 2-wire
- Housing and wetted parts of stainless steel, degree of protection IP 65 or IP 67
- EMC test as per NAMUR 21 and valid EC guidelines

### Options

- Explosion protection (gas)
- Classification per SIL 2
- Accuracy 0.1 %

### Application area

- Chemical and petrochemical industry
- Machinery construction
- General process technology

### Applications

PASCAL Ci is an intelligent, microprocessor-based, 2-wire pressure transmitter that is very user friendly. An integrated graphics display with text-oriented, menu-driven user guidance allows you to assign parameters in a fast and easy manner. You can make all settings with the three buttons on the transmitter. The device offers you another important benefit: you can choose your measuring range and trim without having to remove the device. You can select a bar graph or percentage value read-out as well as the measured-value display. You also have the possibility of displaying the output current and the sensor temperature. A choice of menus allows you to enter and call up different parameters and operating states.

### Menu types

You may use the following menus to display information and to select parameters (type series Ci 1000). User guidance is available in English and German.

menu types	description	menu types	description
<b>meas. range selection</b>	definition of start of measuring and end of measuring, without pressure setpoint value	<b>alarm state</b>	definition of output current in case of malfunction
<b>damping</b>	signal damping selection	<b>current balance</b>	adaption of output signal to downstream devices
<b>min-max-value</b>	displaying min- and max-values for pressure, level and temperature	<b>trimming</b>	definition of start of measuring and end of measuring with pressure setpoint value
<b>output function</b>	transmission function: linear switchable, inverse or root function or function table	<b>table function</b>	output signal can be selected at will with max. 12 points
<b>engineering units</b>	engineering unit selection with automatic conversion e.g., mWC, mmHg, mbar or PSI	<b>factory data</b>	accept factory initial setting
<b>measuring circuit test</b>	generating a defined output signal (current sensing)	<b>language</b>	menu in German/English language available

**Technical Data**

measuring ranges: all measuring spans within the measuring limits

nominal ranges	measuring ranges <sup>3)</sup>		measuring span		overload limits	adjustable engineering units						
			min.	max.		mbar	bar	mmHg	mWC	KPa	psi	%
160 <sup>2)</sup> mbar rel.	-160...160 mbar rel.	16 mbar	320 mbar	1 bar rel.	x		o	o	o	o	o	o
1000 mbar rel.	-1000...1000 mbar rel.	100 mbar	2000 mbar	6 bar rel.	x		o	o	o	o	o	o
4000 mbar rel.	-1000...4000 mbar rel.	200 mbar	5000 mbar	20 bar rel.	x		o	o	o	o	o	o
16 bar rel.	-1...16 bar rel.	0.8 bar	17 bar	60 bar rel.		x		o	o	o	o	o
40 bar rel.	-1...40 bar rel.	2.0 bar	41 bar	100 bar rel.		x		o	o	o	o	o
100 bar rel.	-1...100 bar rel.	5.0 bar	101 bar	200 bar rel.		x				o	o	o
1000 mbar abs.	0...1000 mbar abs.	100 mbar abs.	1000 mbar abs.	3 bar abs.	x		o	o	o	o	o	o
4000 mbar abs.	0...4000 mbar abs.	200 mbar abs.	4000 mbar abs.	10 bar abs.	x		o	o	o	o	o	o
16 bar abs.	0...16 bar abs.	0.8 bar abs.	16 bar abs.	60 bar abs.		x		o	o	o	o	o

1) different conformity error for spans &gt; 200 bar

2) with diaphragm seal ≥ DN 80, only

3) Long-term vacuum measurements at temperatures above +50°C may cause changes in the properties of the measurement device. Vacuum-proof designs are available upon request.

x standard (preselected)

o unit adjustable

**Case design**

stainless steel with hardened surface

mat. no. 1.4305 (303)

degree of protection with closed case

- standard IP 65, inner chamber aeration via integrated filter
- optional IP 67, inner chamber aeration via connection cable

**Electrical connection**

cable entry conduit thread 11 STR for cable diameter 5...10 mm

terminal screw connection up to 2.5 mm<sup>2</sup>**Process connection**

connection: G 1/2 B per DIN EN 837-1

wetted parts: stainless steel mat. no.

1.4404 (316L)

additional feature: volume reduced dia-

phragm seal connection (welded)

diaphragm process connections see product group D5

**Positioning process connection**

can be mounted in any position, and adjusted to suit with:

- a housing that can be progressively rotated
- adjusted indicating unit (standard orientation):

6 o'clock, options: 3, 9, and 12 o'clock)

**Measuring system**

piezoresistive sensor element

**Filling material**

silicone-free synthetic oil

**Window**

safety glass

**Weight**

approx. 1.2 kg

**Operating temperature range**

ambient temperature -10...+55 °C

process temperature -10...+90 °C

cleaning temperature (CIP) up to 140 °C

with horizontal flange mounting max. 1/2 h

**Allowed storage temperature**

-25...+60 °C

**Influence ambient temperature on transmitter**

with reference to nominal range

temperature range +10...+30 °C

lower range value ≤ 0.1 %/10 K

upper range value ≤ 0.1 %/10 K

temperature range -10...+55 °C

lower range value ≤ 0.2 %/10 K

upper range value ≤ 0.2 %/10 K

**Supply voltage**

standard version

· function range 12...50 V DC

· max. perm. 50 V DC

Ex-design

· perm. voltage range

function range 12...30 V DC

max. perm. 30 V DC

**Output signal**

output signal (2-wire) 4...20 mA	
lower limit	3.8 mA
upper limit	20.8 mA
malfunction lower limit	< 3.6 mA
malfunction upper limit	> 21 mA

**Output function**

adjustable

linear	x
inverse	x
root function	x
function table	12 points

**Display**

graphic display with 4 segment pressure

read-out

read-out display

- pressure
  - percent
  - output signal
  - sensor temperature
- bar graph 47 segments 0...100 %  
overpressure indicator  
3 button control for parameterizing (plain text)

**Load**

$$R \leq \frac{U - 12 V}{23 \text{ mA}} \text{ (Ohm)}$$

**Damping**

digital filter (only current output)

0...30 s selectable in steps of 0.2 s

basic electrical damping 0.2 s

**Measuring cycle**

standard: typ. 0.8 s

**Current sensing function**

3.6...21.5 mA selectable in steps of 0.01 mA

**Non-conformity of a curve**

with reference of nominal range

≤ 0.2 % (fixed point adjustment)

≤ 0.1 % as option

**Long-term drift**

with reference to nominal range

typ. ≤ 0.1 %/year

**Overload influence**

within the overload limits, within permissible error tolerances with static loading

**Certificates/tests**

EMC directives	2004/108/EG
Interference emission	EN55011
Noise immunity	EN61000-4-2:2001- EN61000-4-6:2001 EN61000-4-16/ NAMURNE21:1998

Ex approval

TÜV 99 ATEX 1414 X

type of ex-protection:

 II 1/2G Ex ia IIC T4/T5/T6

T <sub>a</sub> [°C]	T <sub>m</sub> [°C]	temperature class
40 °C	40 °C	T6
60 °C	50 °C	T5
70 °C	60 °C	T4

T<sub>a</sub> = ambient temperatureT<sub>m</sub> = medium temperature

extension of temperature range: see "special conditions".

Electrical data

input circuit for type of protection "Intrinsic safety" Ex ia IIC (terminal 1+, 2- and GND) only for connection to a certified intrinsically safe circuit

U<sub>i</sub> = 30 VI<sub>i</sub> = 150 mAP<sub>i</sub> = 1 W

The effective internal inductances and capacitances are negligibly small.

Classification per SIL 2

TÜV-Reg.-No. 44 207 09 555694.

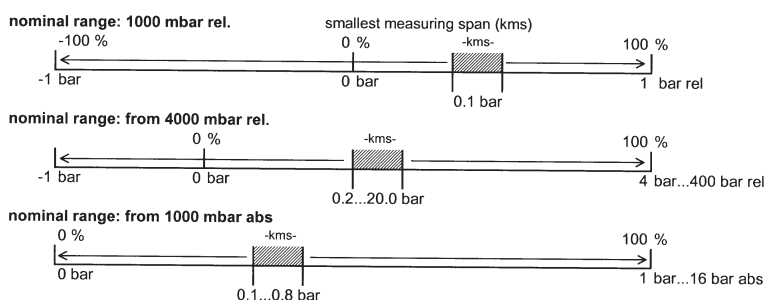
**Information on other models upon request or see to order details****Measuring range/measuring span/measuring limits**

**Dimensions**

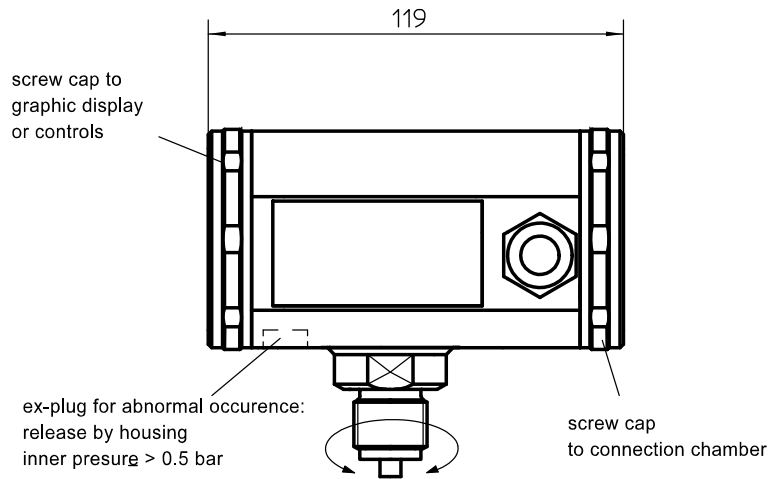

case opposite connection sleeve about ± 170° infinitely rotatable

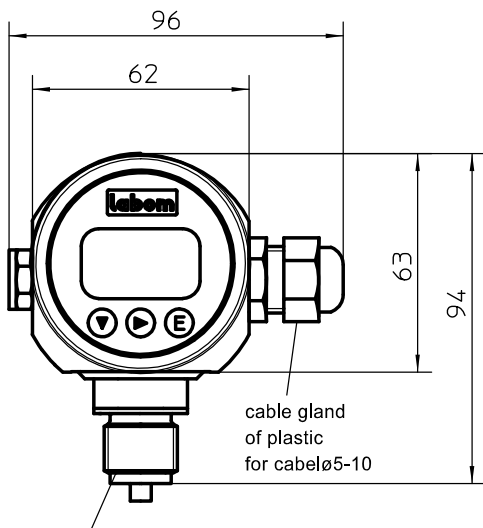

G1/2B per DIN EN 837-1

Standard

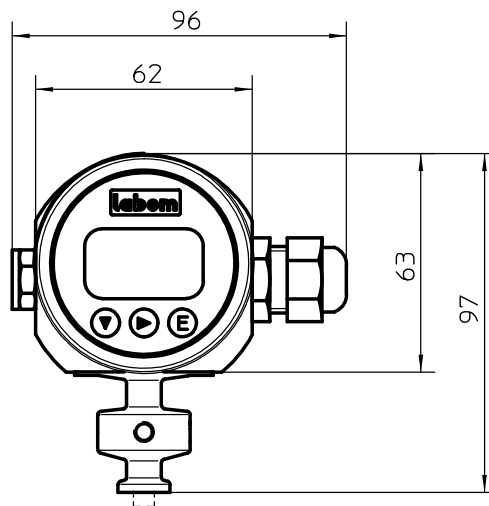

welded diaphragm seal connection (volume reduced) for diaphragm seals see product group D5

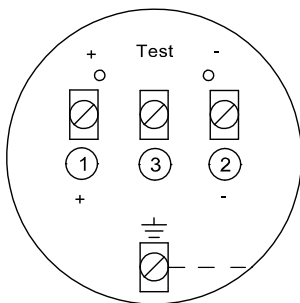

**Connection diagram/connection examples**

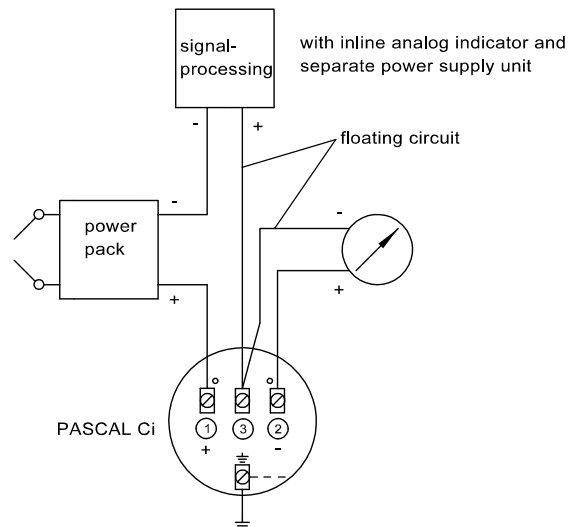
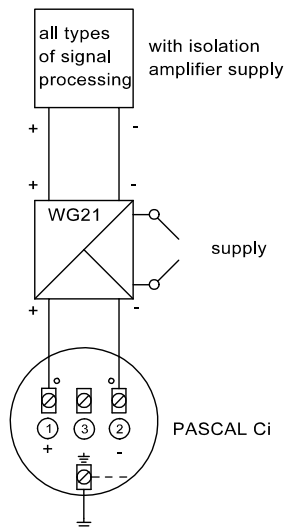

- 1 = + supply
- 2 = - supply
- 3 = vacant terminal
- ⊕ = earth terminal is connected with the case
- Test = connection for testing equipment for uninterrupted current measurement



**Order Details** - please give additional specifications for models not listed -

Pressure transmitter PASCAL Ci with graphic display		C1101 .																	
version	· standard	0																	
	· Ex-protection, types of ex-protection as follows	1																	
nominal range	160 mbar rel. (in combination with external diaphragm seal only)	A1009																	
	1000 mbar rel.	A1053																	
	4000 mbar rel.	A1056																	
	16 bar rel.	A1059																	
	40 bar rel.	A1061																	
	100 bar rel.	A1063																	
	1000 mbar abs.	B1053																	
	4000 mbar abs.	B1056																	
parameterization	· factory settings (standard) <sup>2</sup>	F1																	
	· as per customer's specification (pls. specify)	F2																	
output signal	· 4...20 mA, standard	H11																	
	· 4...20 mA, with HART-protocol	H21																	
degree of protection	· IP 65	T2																	
	· IP 67 <sup>3</sup>	T1																	
<b>additional features (to be indicated in case of need, only)</b>																			
non-conformity of a curve	· ≤ 0.1 % <sup>1</sup>	Q1																	
process connection via diaphragm seal <sup>4</sup>	· volume reduced for diaphragm seal (welded) .....	K1085																	
	connection via capillary	· stainless steel capillary, welded	K4085																
		· stainless steel capillary with protective tube	K4185																
	· as per indication	K9999																	
positioning process connection	· 9 o'clock	R2																	
	· 3 o'clock	R3																	
	· 12 o'clock	R4																	
explosion protection	·  II 2G Ex ia IIC T4/T5/T6, Standard	S68																	
	·  II 1/2G Ex ia IIC T4/T5/T6	S66																	
functional safety as per EN 61508, classification per SIL 2		W2602																	
<b>order code (example)</b>		C11010	A1053	F1	H11	T2													
<b>accessory</b>																			
HART communication	· Software COMLINE.HART		MC1010																
	HART Modem	· RS 232-Interface	MC1020																
		· USB-Interface	MC1040																
		· USB-Interface, Ex	MC1041																

<sup>1</sup> different conformity error for spans > 200 bar<sup>2</sup> **Factory adjustment:**

Measuring range calibrated:	0...nominal range for 4...20 mA
Damping:	0 s
Signal output upon error:	< 3.6 mA
Pressure unit:	bar or mbar
Signal evaluation:	linear
User-guidance language:	German

<sup>3</sup> standard with absolute pressure<sup>4</sup> diaphragm seal see product group D5