

Introduction

These operating instructions refer to installation, commissioning, servicing and adjustment. Statutory regulations, valid standards, additional technical details in the relevant data sheet, details of the type plate and any additional certificates are to be observed along with these operating instructions.



Safety instructions

- Installation, operation and maintenance of the instrument may be executed by authorized personnel, only, using suitable equipment.
- Warning: If the instrument is used incorrectly it is possible that serious injuries or damage can occur!
- Prior to the disassembly of the pressure transmitter the impulse ducts between the measuring transmitter and the process have to be locked and relieved from pressure.
- The standard nominal pressure rating and the permissible operating temperature of the gasket should be observed for all process connections. Operation outside the allowed nominal pressure rating, especially with clamp connections, is only possible with suitable clamps. In this case, note DIN 32676 for stipulations on heat resistance.
- Pressure transmitters that are mechanically defective can cause injuries or give rise to process faults. Suitable precautions should be taken to avoid this.



CE marking



The CE marking on the instruments certifies compliance with valid EU directives for bringing products to market within the European Union. The following directives are met:

EMC directives	EMC	2004/108/EG
Pressure Equipment Directive	PED	97/23/EG
Ex directive	ATEX	94/9/EG



Ex approval

Electrical equipment in hazardous areas should only be installed and commissioned by competent personnel. Modifications to devices and connections destroy the operating safety, the ex-proofing and the guarantee. The limit values detailed in the certificate of conformity are to be observed.

Certificate no.	TÜV 99 ATEX 1414 X
Ex-protection	 II 1/2 G Ex ia/ib IIC T4/T5/T6
	 II 2 G Ex ia IIC T4/T5/T6

Mounting and operating

- Before mounting the instrument ensure that pressure range, overpressure resistance, media compatibility, thermostability and pressure port are suitable for the process at hand.
- Conduct process installation before electrical installation.
- Measuring instruments that should not have any oil or grease residues in the pressure port are marked „Free of oil and grease“.
- Gaskets must be chosen that are suited to the process connection and resistant to the measured medium.
- Check for pressure tightness when commissioning the transmitter.
- Do not insulate the temperature decoupler, as this would reduce the decoupling effect. Follow DIN 32676.
- Wire up the instrument with power switched off.
- Instruments with case protection IP67 and pressure ranges to 16 bar/ 250 psi are aerated through the connection cable. Place an aeratable cable in an aeratable connection chamber during mounting. This will compensate for atmospheric variations.

- The instrument can only be protected against electromagnetic interference (EMC) if the conditions for screening, earthing, wiring and potential isolation are met during installation.
- The mounting position should be taken into consideration when checking the zero output. Standard transmitters are adjusted at the factory for vertical mounting. Changes to the mounting position can cause zero shifts at pressure ranges < 2 bar. These drifts can be corrected by adjustment on site (see zero point correction).
- When the instrument is opened any contact with the electrical connections can affect the signals. This situation can be avoided by switching off the supply voltage or by disconnecting the signal circuit.
- The types of protection IP65/IP67 are only achieved, when both threaded rings have been screwed tight after electrical connection/parameterization.
- The instrument requires no maintenance.

Instructions for the operation with diaphragm seal

- To avoid soiling and damage remove protective cap or wrapping in front of the separating diaphragm before mounting.
- Do not touch the flush mounted separating diaphragm, as there is a danger of deformation at measuring ranges to 10 bar / 150 psi. Instrument zero point and measuring characteristics could also be affected.
- Measuring instrument and diaphragm seal are a closed system and should not be separated .
- Avoid overtightening the process screw joints as this can result in zero displacements at the pressure transmitter (fixing error).
- When using systems with capillary for vacuum measurements always mount the pressure transmitter underneath the diaphragm seal. The instruments are set at the factory with pressure transmitter and diaphragm seal at the same height. Correct any differences in height between diaphragm seal and pressure transmitter arising from conditions on site on the pressure transmitter when placing the instrument into operation (see zero-point correction). When correcting for elevation be aware of the adjustment limits.
- Be sure to install and securely fasten the capillary to avoid vibrations. Roll up overlengths with a minimum radius of 20-25 cm. Shock and changes in temperature can impact on measurements.
- Process and ambient temperatures can cause zero displacements at the pressure transmitter with some system designs. We can supply you with an error analysis.



Zero-point correction

Should you need to adjust the zero-point on site, then undo the front threaded ring to gain access to the controls. You will find instructions on using the keyboard in your manual. To set the measuring span, you should apply an accurate reference pressure.

Please check the User Guidance for further information regarding operation and parameterization.

 **Further information required? Hotline +49 (0) 4408 804-444**

Technical Data

Case design

with hardened surface mat. no. 1.4305

Protection type with closed case

IP65 inner chamber aeration via integrated filter
IP67 inner chamber aeration via connection cable

Electrical connection

Cable entry for cable diameter 5...10 mm
terminal screw connection 2.5 mm²

Temperature ranges

ambient temperature: -10°C...+55 °C
storage temperature: -25°C...+60 °C
process temperature: -10°C...+90°C
cleaning temperature (CIP) up to max. +140°C
with horizontal flange mounting max. ½ h

Measuring accuracy

linearity error incl. hysteresis ≤+ 0.2 % f.s.
optional ≤+ 0.1 % f.s.
accuracy of adjustment: ≤± 0.1 % f.s.
temperature effect see data sheet

Supply voltage

standard version
· function range 12...50 V DC
· max. permiss. 50 V DC

Ex-design

· permiss. voltage range
function range 12...30 V DC
max. permiss. 30 V DC

Signal output

4...20 mA 2-wire circuitry

Current limitation in output signal

max. output current approx. at 21.5 mA

Adjusting range

You may adjust zero point and measuring span to wide limits from the keyboard. (see manual for details)

Burden

$$R \leq \frac{U - 12 \text{ V}}{23 \text{ mA}} \text{ (Ohm)}$$

System filling

silicone-free synthetic oil (standard)

Installation position

any, standard: adjusted at factory for vertical mounting

Certificates/tests

EMC directives 2004/108/EG
Interference emission EN55011
Noise immunity EN61000-4-2:2001-
EN61000-4-6:2001
EN61000-4-16/
NAMUR NE21:1998

Caution

Switch off device if it is installed in zone 0 and in temperature class T5 and T6 and it falls!

Further details see data sheet D4-015

Dimensions/case/process connection

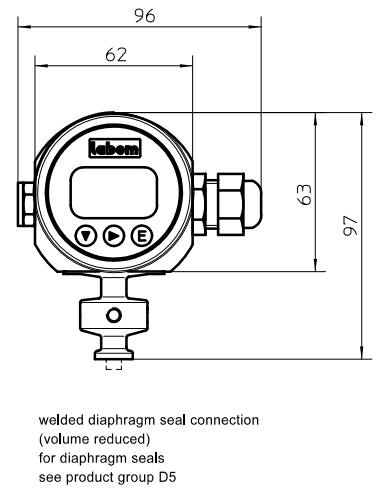
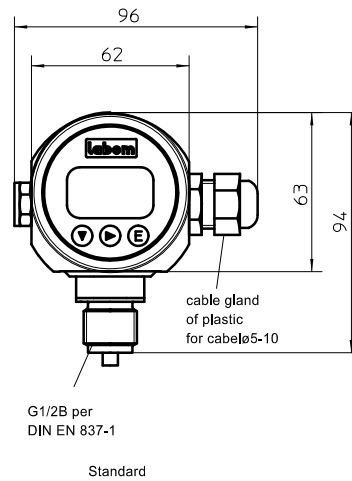
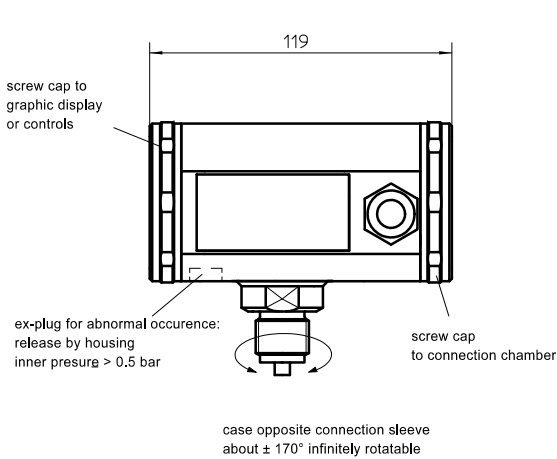

Connection diagram

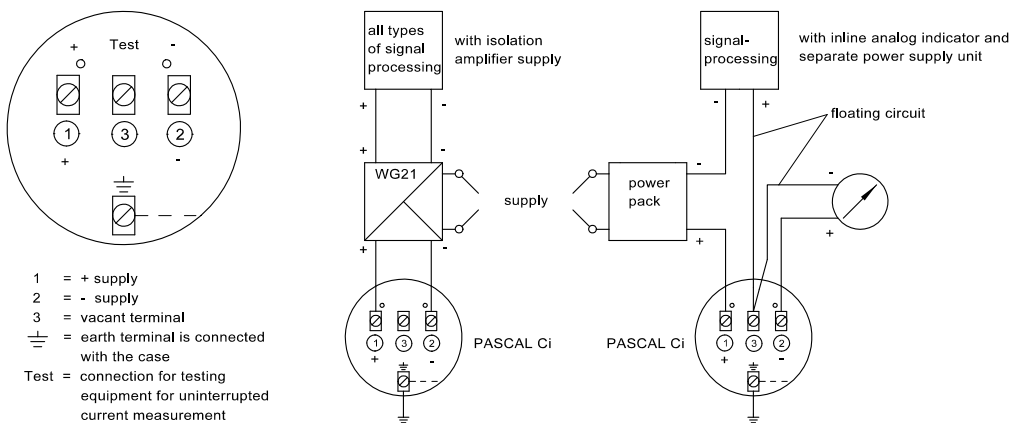



Translation

EC TYPE-EXAMINATION CERTIFICATE

- (1)
- (2) Equipment or protective system intended for use in potentially explosive atmospheres - **Directive 94/9/EC**
- (3) EC-Type Examination Certificate Number



TÜV 99 ATEX 1414 X

- (4) Equipment: Pressure Transmitter type CI...1 S..6.
- (5) Manufacturer: LABOM Mess- und Regeltechnik GmbH
- (6) Address: Im Gewerbepark 13
D-27798 Hude
- (7) This equipment or protective system and any acceptable variation thereto is specified in the schedule to this certificate and the documents therein referred to.
- (8) The TÜV NORD CERT GmbH & Co. KG, TÜV CERT-Certification Body, notified body number N° 0032 in accordance with Article 9 of the Council Directive of the EC of March 23, 1994 (94/9/EC), certifies that this equipment or protective system has been found to comply with the Essential Health and Safety Requirements relating to the design and construction of equipment and protective systems intended for use in potentially explosive atmospheres given in Annex II to the Directive.

The examination and test results are recorded in the confidential report N° 99/PX19980.

- (9) Compliance with the Essential Health and Safety Requirements has been assured by compliance with:

EN 50014:1997

EN 50020:1994

- (10) If the sign "X" is placed after the certificate number, it indicates that the equipment or protective system is subject to special conditions for safe use specified in the schedule to this certificate.
- (11) This EC-type examination certificate relates only to the design and construction of the specified equipment or protective system. Further requirements of this Directive apply to the manufacture and placing on the market of this equipment or protective system
- (12) The marking of the equipment or protective system must include the following:

 **II 2 G EEx ia IIC T6**

TÜV NORD CERT GmbH & Co. KG
TÜV CERT-Certification Body
Am TÜV 1
D-30519 Hannover
Tel.: 0511 986-1470
Fax: 0511 986-2555

Head of the
Certification Body



Hanover, 2003-11-12

TÜV NORD CERT GmbH & Co. KG
legal successor of the notified body of
TÜV Hannover/Sachsen-Anhalt e.V.
German original certificate
issued on 1999-04-22



SCHEDULE

(13)

(14) EC-TYPE EXAMINATION CERTIFICATE N° TÜV 99 ATEX 1414 X

(15) Description of equipment

The pressure transmitter type Cl...1 S..6. consists of a piezo resistive pressure sensor and an integrated temperature detector, which is used for temperature compensation.

Electrical data

Input circuit in type of protection „Intrinsic safety“ EEx ia IIC (Terminals 1+, 2- and GND) resp. EEx ib IIC only for connection to a certified intrinsically safe circuit

The maximum permissible ambient temperature, the marking and the „electrical data“ in dependence of the type have to be taken from the following table:

Table with 6 columns: Type, Marking, Maximum permissible ambient temperature, Ui, Ii, Pi. Rows include types S..61 to S..66 with their respective specifications.

The effective internal capacitance and inductance are negligibly small.

Test output only for short time connection to not earthed test devices without own energy source

(16) Test documents are listed in the test report No. 99/PX19980.

(17) Special condition for safe use

It has to be ensured, that potential compensation exists in the complete course of the wiring.

(18) Essential Health and Safety Requirements

no additional ones



Translation

1. SUPPLEMENT to

EC TYPE-EXAMINATION CERTIFICATE No. TÜV 99 ATEX 1414 X

of the company: labom Mess- und Regeltechnik GmbH
Im Gewerbepark 13
D-27798 Hude

In the future, the pressure transmitter type CI...1 S..6. may also be manufactured according to the test documents listed in the test report. The changes refer to the construction of the pressure sensor and the sensor circuit board as well as to the electrical data.

The pressure port may be erected in explosion hazardous areas that require apparatus of the category 1.

The maximum permissible ambient temperature on the housing Ta the maximum permissible medium temperature on the pressure port TM and the temperature class then have to be taken from the following table:

Table with 3 columns: Ta [°C], TM [°C], Temperature class. Rows: (40°C, 40°C, T6), (60°C, 50°C, T5), (70°C, 60°C, T4)

Extension of the temperature range: see "Special conditions for safe use"

Electrical data

Input circuit in type of protection „Intrinsic safety“ EEx ia IIC
(Terminals 1+, 2- and GND)

only for connection to a certified intrinsically safe circuit
Maximum values:

- Ui = 30 V
Ii = 150 mA
Pi = 1 W

The effective internal inductances and capacitances are negligibly small.

The pressure transmitter type CI...1 S..6. also meets the requirements of
EN 50 020:2002 and
EN 50 284:1999 .

The marking of the pressure transmitter
according to this 1. supplement reads II 1/2 G EEx ia II C T6.

Special conditions for safe use

1. The pressure port of the pressure transmitter type CI...1 S..6. is allowed to be operated in an explosion hazardous atmosphere, which requires apparatus of the category 1, only if atmospheric conditions exist (Temperature from -20°C to 60°C , pressure from 0,8 bar to 1,1 bar).

If the explosion hazardous atmosphere does not require apparatus of the category 1, the maximum permissible ambient temperature in the area of the pressure port T_M may be taken from the following table:

T_a [$^{\circ}\text{C}$]	T_M [$^{\circ}\text{C}$]	Temperaturklasse
40°C	40°C	T6
60°C	60°C	T5
70°C	70°C	T4

Operating temperatures and -pressures have to be taken from the regarding data of the manufacturer (manual), if no explosion hazardous gas mixtures exist.

2. It has to be ensured, that potential compensation exists in the complete course of the wiring.

Test documents are listed in the test report N° 03YEX550256.

TÜV NORD CERT GmbH & Co. KG
TÜV CERT-Certification Body
Am TÜV 1
D-30519 Hannover
Tel.: 0511 986-1470
Fax: 0511 986-2555

Hannover, 2003-11-12

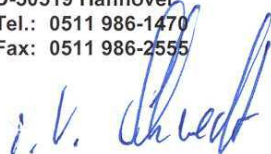

Head of the
Certification Body